



Designated according to The Construction Products (Amendment etc.) (EU Exit) Regulations 2020 (as amended 2022)

UK Technical Assessment	UKTA-0836-25/7376 of 22/05/2025
Technical Assessment Body issuing the UK Technical Assessment:	British Board of Agrément
Trade name of the construction product:	ThermoDrive-V2
Product family to which the construction product belongs:	Product Area Code 33 Plastic anchor for fixing of external thermal insulation composite systems with rendering
Manufacturer:	KLIMAS Sp. z o.o. ul. Wincentego Witosa 135/137 Kuźnica Kiedrzyńska PL 42-233 Mykanów Poland
Manufacturing plant(s):	Plant 1, Poland Plant 2, Poland
This UK Technical Assessment contains:	20 pages including 3 Annexes which form an integral part of this Assessment
This UK Technical Assessment is issued in accordance with The Construction Products (Amendment etc.) (EU Exit) Regulations 2020 (as amended 2022) on the basis of:	UKTA 330196-01-0604 "Plastic anchors made of virgin or non-virgin material for fixing of external thermal insulation composite systems with rendering"

Communication of this UK Technical Assessment, including transmission by electronic means, shall be in full. However, partial reproduction may be made with the written consent of the British Board of Agrément. Any partial reproduction must be identified as such.

1. Technical description of the product

The screwed-in anchor ThermoDrive-V2 with a plate consists of an anchor sleeve made of polyethylene (virgin material) and an accompanying specific screw made of galvanized steel or of steel with zinc flake coating or of stainless steel.

The description of the products is given in Annex A.

2. Specification of the intended use(s) in accordance with the applicable UK Assessment Document (hereinafter UKAD)

The performances given in Section 3 are only valid if the anchor is used in compliance with the specifications and conditions given in Annex B.

The provisions made in this UK Technical Assessment are based on an assumed working life of the anchor of 25 years. The indications given on the working life cannot be interpreted as a guarantee given by the producer or BBA, but are to be regarded only as a means for choosing the right products in relation to the expected economically reasonable working life of the works.

3. Performance of the product and references to the methods used for its assessment

3.1. Mechanical resistance and stability (BWR 1)

Not relevant.

3.2. Safety in case of fire (BWR 2)

Not relevant.

3.3. Health, hygiene and the environment (BWR 3)

Not relevant.

3.4. Safety and accessibility in use (BWR 4)

Essential characteristic	Performance
Characteristic resistance under tension load	Annexes C1, C2 and C3
Edge distances and spacings	Annex B2
Plate stiffness	Annex C4
Displacements	Annex C4

3.5. Protection against noise (BWR 5)

Not relevant.

3.6. Energy economy and heat retention (BWR 6)

Essential characteristic	Performance
Point thermal transmittance	Annex C4

3.7. Sustainable use of natural resources (BWR 7)

No performance assessed.

4. Assessment and verification of constancy of performance (hereinafter AVCP) system applied

4.1. System of assessment and verification of constancy of performance

According to UKAD No. 330196-01-0604 and Annex V of the Construction Products (Amendment etc.) (EU Exit) Regulations 2020 (as amended 2022) 305/2011 as brought into UK law and amended, the system of assessment and verification of constancy of performance (AVCP) 2+ applies.

5. Technical details necessary for the implementation of the AVCP system, as provided for in the applicable UKAD

Technical details necessary for the implementation of the AVCP system are laid down in the control plan deposited with the British Board of Agrément and made available to the UK Approved Bodies involved in the conformity attestation process.

5.1. UKCA marking for the product/ system must contain the following information:

- Identification number of the Approved Body
- Name/ registered address of the manufacturer of the product/ system
- Marking including date of Marking and the intended use as stated in the Designated technical specification
- Unique identification code of the product type
- The reference number of the Declaration of Performance
- The level or class of the performance declared
- The reference to the Designated technical specification applied
- UKTA number.

On behalf of the British Board of Agrément



Date of Issue: 22 May 2025

Hardy Giesler
Chief Executive Officer



British Board of Agrément,
1st Floor Building 3,
Hatters Lane,
Croxley Park
Watford
WD18 8YG

ANNEX A1

Product description / Installation conditions / Surface mount, immersed mount

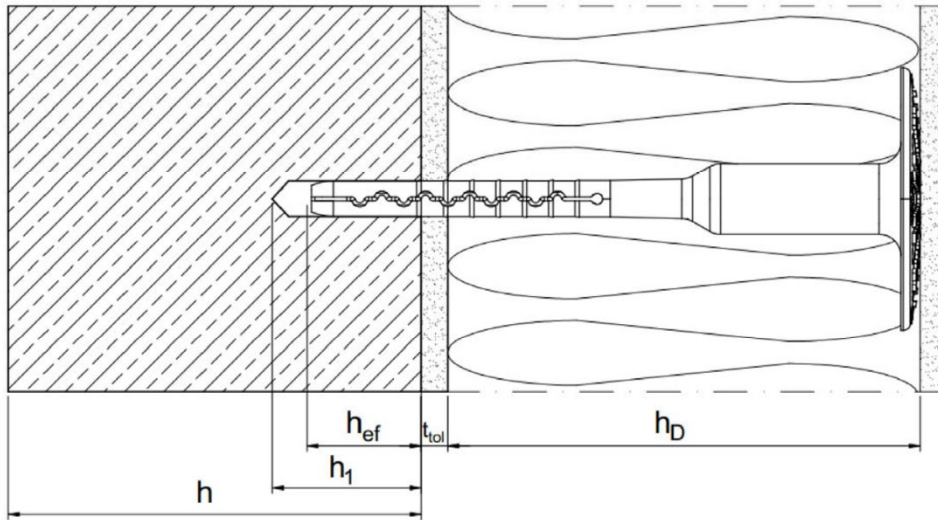

Surface mount

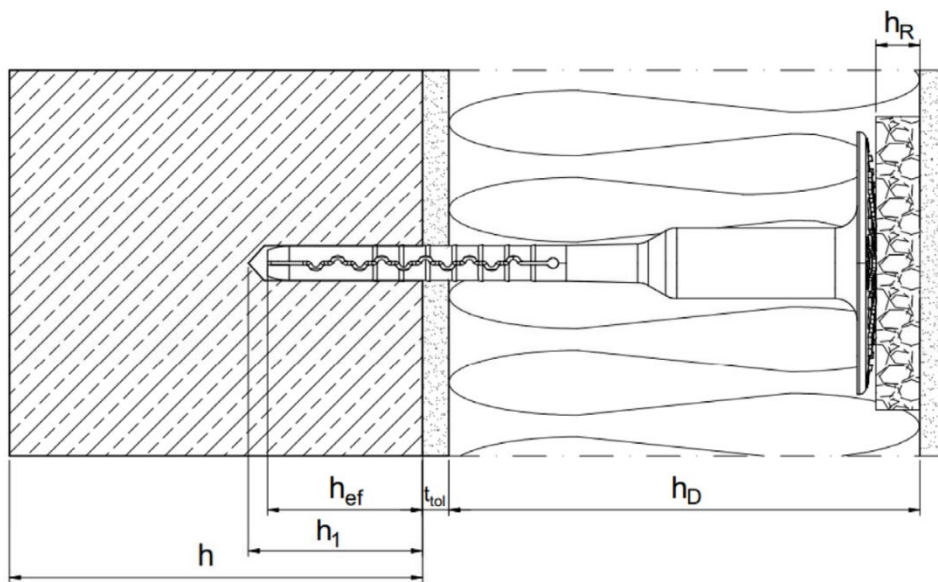

Immersed mount

- Legend:
- h_D = thickness of insulation material
 - h_{ef} = effective anchorage depth
 - h = thickness of member (wall)
 - h_1 = depth of drilled hole to deepest point
 - t_{tol} = thickness of equalizing layer or non-load-bearing coating
 - h_R = thickness of insulation cover

ANNEX A2

Product description / Marking and dimension of the anchor sleeve and specific screw

Marking for anchor sleeve:
 Identifying Mark (KLIMAS)
 Anchor sleeve -V2
 Anchor size - 8xL_k
 Base material group (ABCDE)

Accompanying specific screw

Table A1: Dimensions								
Anchor Type	Anchor sleeve					Specific screw		
	D _k [mm]	d _{nom} [mm]	min L _a [mm]	max L _a [mm]	min h _{ef} [mm]	d _s [mm]	min L _s [mm]	max L _s [mm]
ThermoDrive-V2	60	8	135	475	25/45*	5.8	75	295

* effective anchorage depth for base material group E

Determination of maximum thickness of insulation h_D [mm] for ThermoDrive-V2:

$$h_D = L_a - t_{tol} - h_{ef} \quad (\text{e.g. } L_a = 195; t_{tol} = 10)$$

e.g. $h_D = 195 - 10 - 25$
 $h_{Dmax} = 160$

ANNEX A3
Product description / Materials

Table A2: Materials

Name	Materials
Anchor sleeve	Polyethylene (natural, grey, blue or black) – virgin material
Screw	Steel, electro galvanized $\geq 5 \mu\text{m}$ in accordance with EN ISO 4042 : 2022 or non-electrolytically applied zinc flake coatings $\geq 5 \mu\text{m}$ in accordance with EN ISO 10683 : 2018 or stainless steel grade 1.4301, 1.4306, 1.4307, 1.4567 (AISI 304) or 1.4401, 1.4404 ,1.4571, 1.4362, 1.4578 (AISI 316), in accordance with EN 10088-3 : 2014
Insulation cover	KS, KSV: Polystyrene (EPS), colour: white KSG, KSVG: Polystyrene (EPS), colour: grey EDMW: mineral wool (MW), colour: natural

Table A3: Additional slip on plates - diameters and material

Plate type	Outer diameter [mm]	Material
TDX-P-90	90	Polyethylene (natural, grey, blue or black)
TDX-90	90	Polyamide +GF (natural or grey)
TDX-P-140	140	Polyethylene (natural, grey, blue or black)
TDX-140	140	Polyamide +GF (natural or grey)
TDMW-110	110	Polyamide +GF (natural or grey)
TDMW-P-110	110	Polyethylene (natural, grey, blue or black)
TDPS-60	63	Polyamide +GF (natural or grey)
TDPS-P-60	63	Polyethylene (natural, grey, blue or black)

ANNEX A4
Product description / Additional slip on plates with ThermoDrive-V2

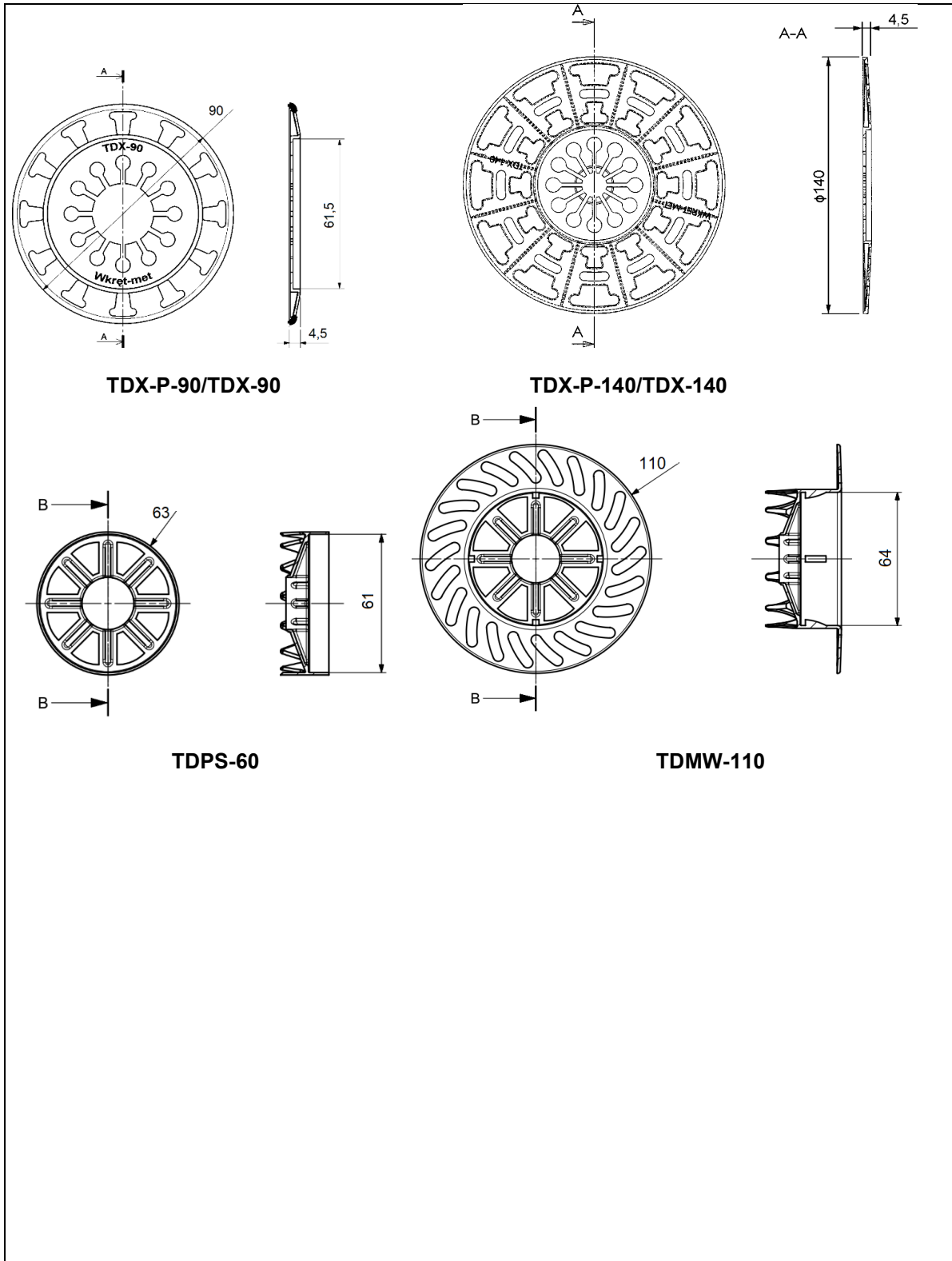

ANNEX A5

Product description / Additional tools and insulation caps

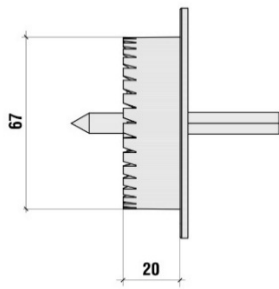

**Drill tool WK-FT/WK-FM
for immersed installation**

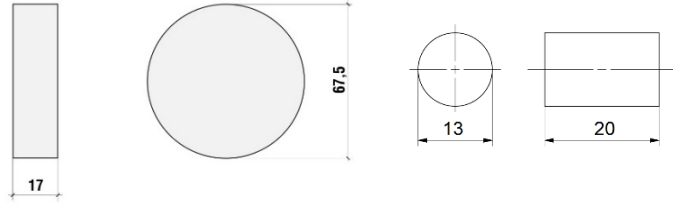

Insulation cap KS/ KSG or EDMW and KSV

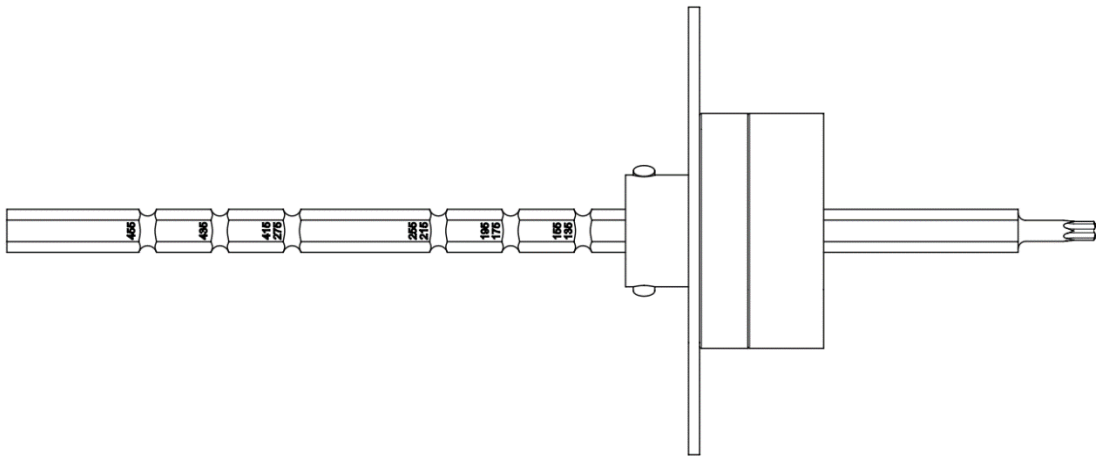

Additional mounting tool ThermoDrive-V2

ANNEX B1

Intended use / Specifications

Anchorage subject to:

The anchor may only be used for transmission of wind suction loads without bracket and must not be used for the transmission of dead loads of the thermal insulation composite system).

Base materials:

- Compacted normal weight concrete without fibres, strength classes \geq C12/15 (base material group A), according to Annex C1
- Solid masonry (base material group B), according to Annex C1
- Hollow or perforated masonry (base material group C), according to Annexes C1 and C2
- Lightweight aggregate concrete (base material group D), according to Annex C3
- Autoclaved aerated concrete (base material group E), according to Annex C3
- For other base materials of the base material groups A, B, C, D or E the characteristic resistance of the anchor may be determined by job site tests according to EOTA Technical Report TR 051 edition April 2018.

Temperature range:

- 0°C to +40°C (maximum short term temperature +40°C and maximum long term temperature +24°C).

Design:

- The anchorages are designed under the responsibility of an engineer experienced in anchorages and masonry work with the partial safety factors $g_M = 2.0$ and $g_F = 1.5$, if there are no other national regulations
- Verifiable calculation notes and drawings with anchor positions are prepared taking into account of the loads to be anchored
- Fasteners are only to be used for multiple fixings of external wall insulation system (EWIS), according to UKAD 330196-01-0604.

Installation:

- Holes must be drilled by the drill modes according to Annex C1
- Anchor installation must be carried out by appropriately qualified personnel and under the supervision of the person responsible for technical matters of the site
- Installation must be executed in temperature from 0°C to +40°C
- Exposure to UV due to solar radiation of the anchor not protected by rendering by the mortar must not exceed \leq 6 weeks.

ANNEX B2

Intended use / Installation characteristics, minimum thickness of base material, edge distance and spacing

Table B1: Installation parameters for ThermoDrive-V2

		ThermoDrive-V2	ThermoDrive-V2
Base material group		ABCD	E
Drill hole diameter	d_0 [mm] =	8	8
Cutting diameter of drill bit	d_{cut} [mm] ≤	8.45	8.45
Depth of drilled hole to deepest point	h_1 [mm] ≥	35/55 ⁽¹⁾	55/75 ⁽¹⁾
Effective anchorage depth	h_{ef} [mm] ≥	25	45

(1) Immersed mount using tool ThermoDrive-V2

Table B2: Anchor distances and dimensions of members

Minimum spacing	$s_{min} ≥$ [mm]	100
Minimum edge distance	$c_{min} ≥$ [mm]	100
Minimum thickness of member	$h ≥$ [mm]	100
Minimum thickness of member for thin concrete members	$h ≥$ [mm]	40

Scheme of edge distance and spacing

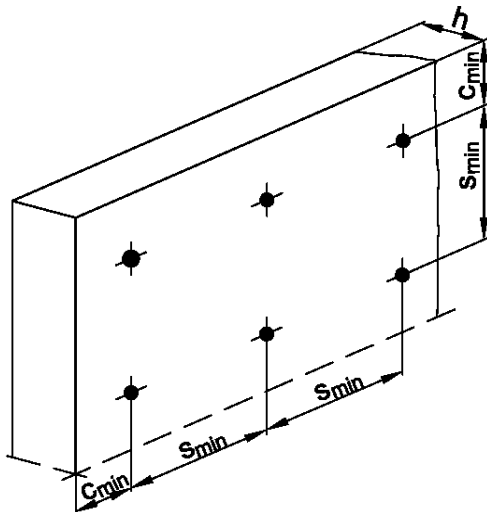

ANNEX B3
Intended use / Surface mount

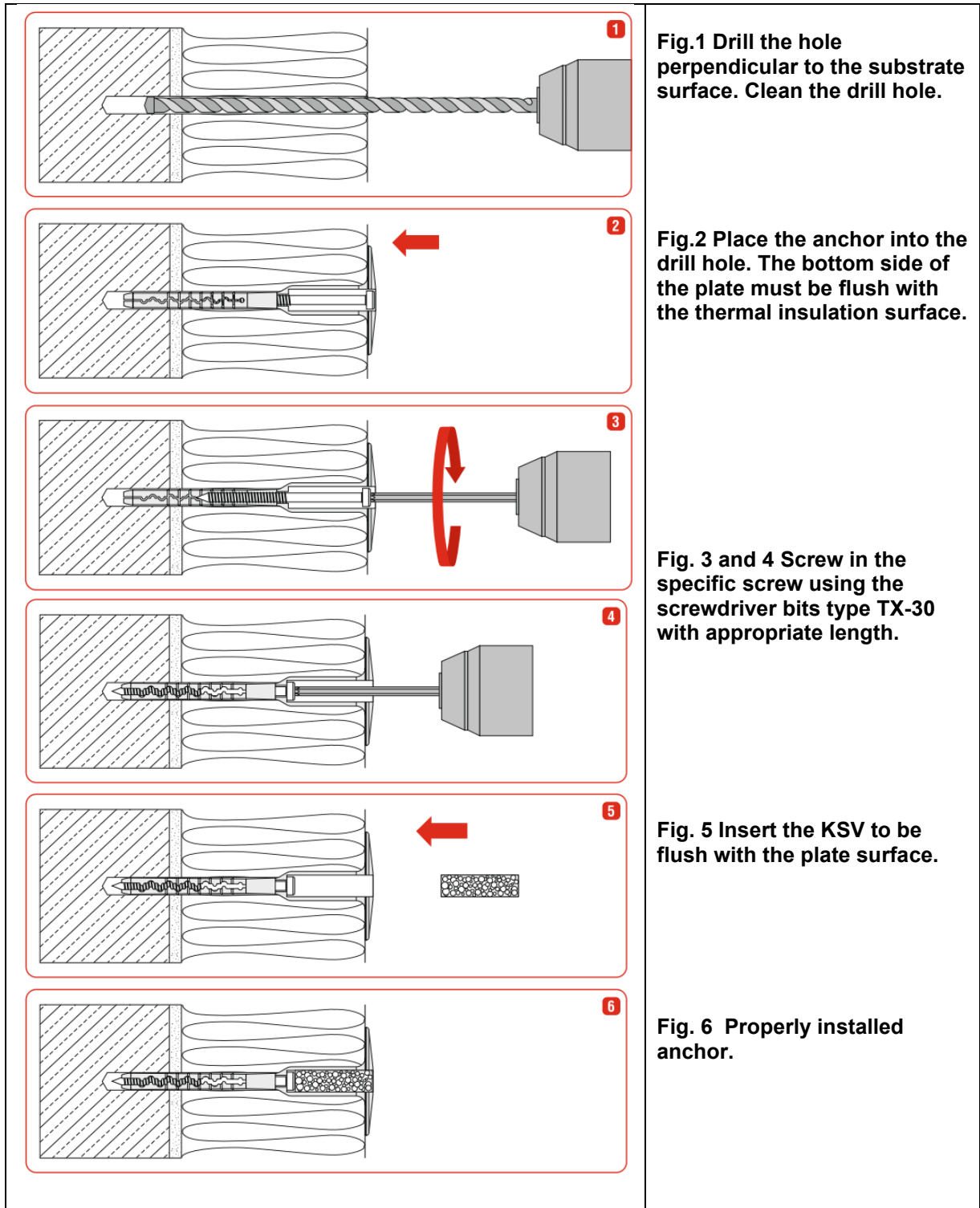

ANNEX B4

Intended use / Immersed mount with insulation cap

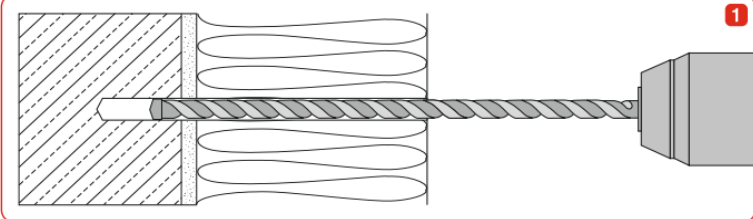
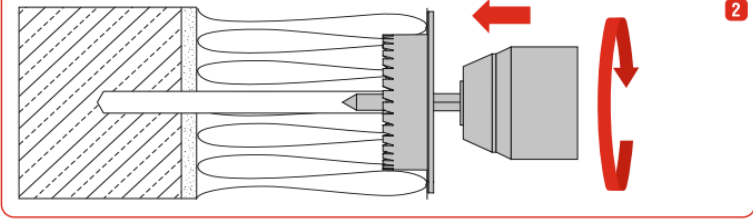
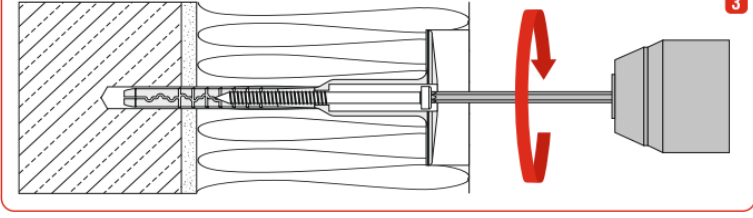
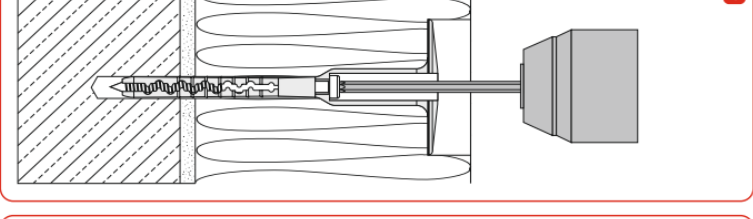
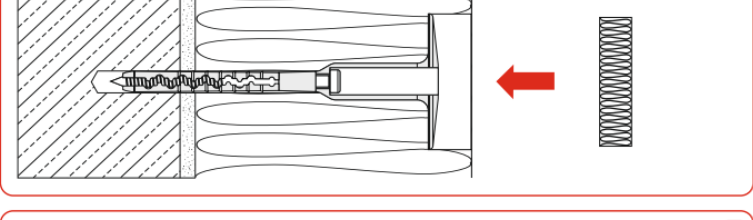
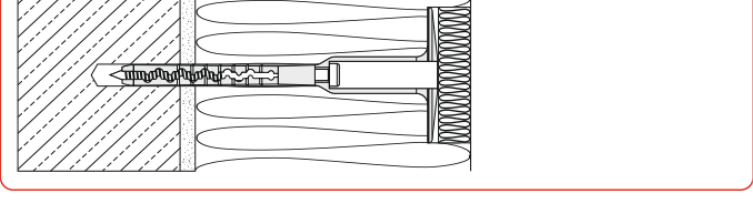
	<p>Fig. 1 Drill the hole perpendicular to the substrate surface. Clean the drill hole.</p>
	<p>Fig. 2 Drill the recess for immersed installation with appropriate drilling tool WK-FT/WK-FM.</p>
	<p>Fig. 3 and 4 Screw in the specific screw using the screwdriver bits type TX-30 with appropriate length.</p>
	
	<p>Fig. 5 Insert the insulation cap.</p>
	<p>Fig. 6 Properly installed anchor.</p>

ANNEX B5

Intended use / Immersed mount using tool ThermoDrive-V2 with installation cap

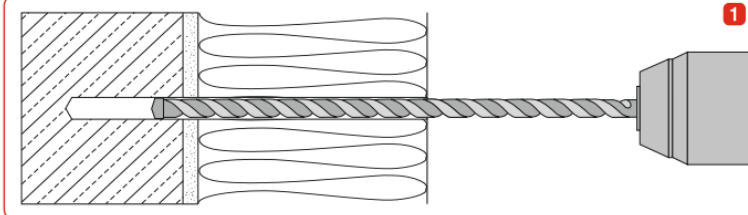
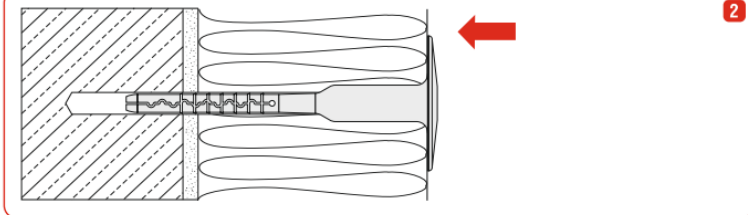
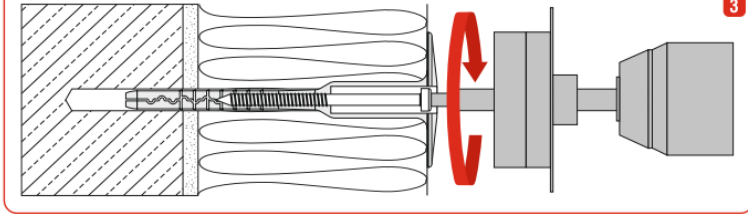
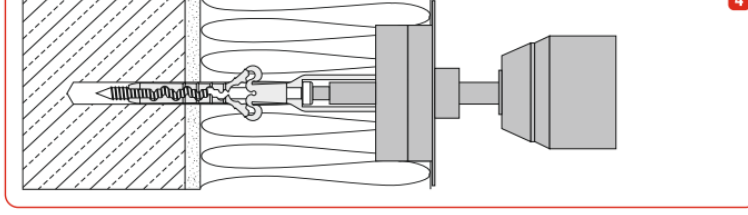
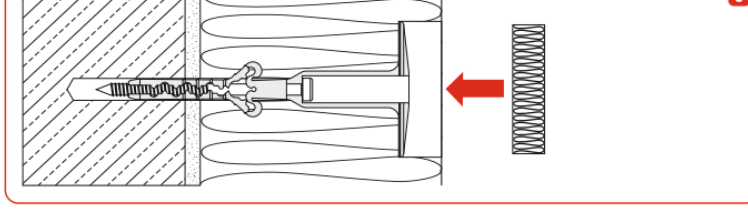
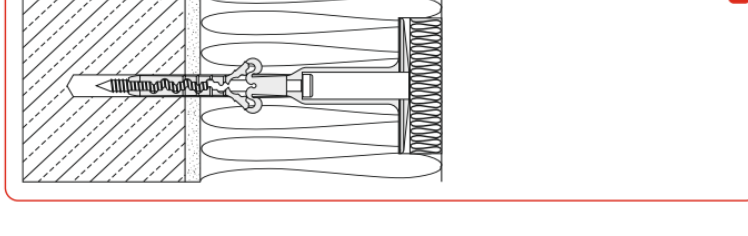
	<p>Fig. 1 Drill the hole perpendicular to the substrate surface. Clean the drill hole.</p>
	<p>Fig. 2 Place the anchor into the drill hole. The bottom side of the plate must be flush with the thermal insulation surface.</p>
	<p>Fig. 3 and 4 Screw in the specific screw using the tool ThermoDrive-V2.</p>
	
	<p>Fig. 5 Insert the insulation cap.</p>
	<p>Fig. 6 Properly installed anchor.</p>

ANNEX B6

Intended use / Immersed mount with PLATE (TDPS or TDMW) and insulation cap

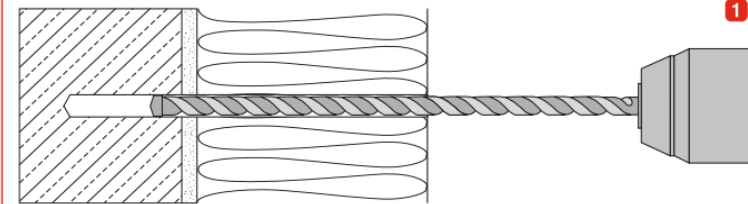
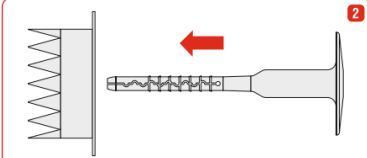
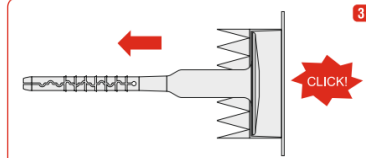
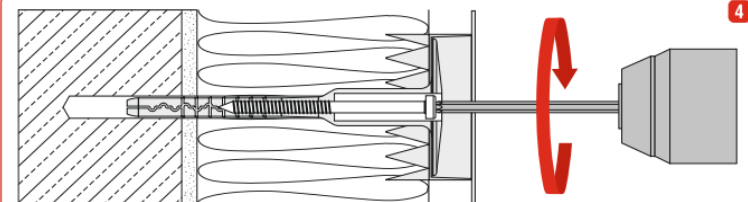
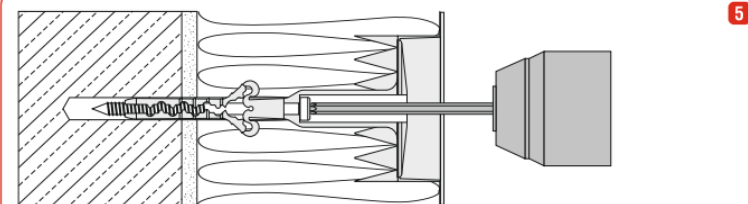
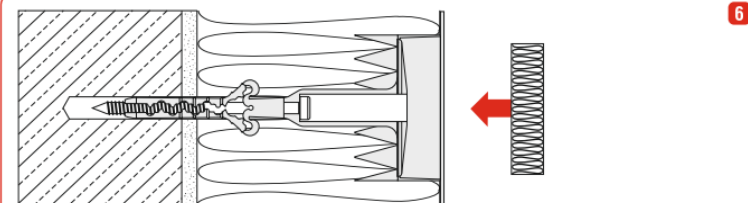
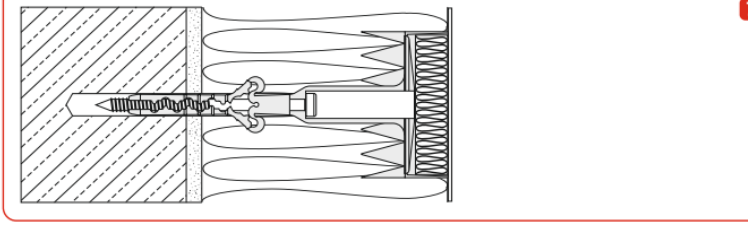
	<p>Fig. 1 Drill the hole perpendicular to the substrate surface. Clean the drill hole.</p>
 	<p>Fig. 2 Assemble anchor and PLATE TDPS or TDMW</p> <p>Fig. 3 Correct assembly is confirmed by a "click".</p>
	<p>Fig. 4 and 5 Screw in the specific screw using the screwdriver bits type TX-30 with appropriate length.</p>
	
	<p>Fig. 6 Insert the insulation cap.</p>
	<p>Fig. 7 Properly installed anchor.</p>

ANNEX C1

Performances / Characteristic resistance of ThermoDrive-V2 – part 1

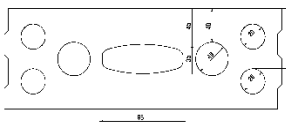
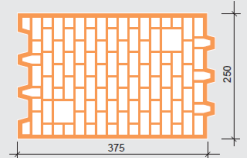
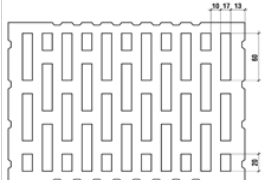
Table C1: Characteristic resistance to tension loads N_{Rk} in concrete and masonry for a single anchor in kN						
Anchor type					ThermoDrive-V2	
Base materials	Bulk density ρ [kg/dm ³]	minimum compressive strength f_b [N/mm ²]	General remarks	Drill method	N_{Rk} [kN]	
Concrete C12/15 as per EN 206 : 2013 + A1 : 2016	≥ 2.2	≥ 20	Compacted normal weight concrete without fibres	Hammer	1.50	
Concrete C16/20 - C50/60 as per EN 206 : 2013 + A1 : 2016	≥ 2.25	≥ 30	Compacted normal weight concrete without fibres	Hammer	1.50	
Thin concrete members (eg weather resistant skin of external wall panels) C16/20 – C50/60	≥ 2.0	≥ 20	Compacted normal weight concrete without fibres Thickness of the thin skin: 100 mm > h \geq 40 mm	Hammer	1.50	
Clay bricks MZ as per EN 771-1:2011+A1:2015	≥ 2.0	≥ 20	Vertically perforation up to 15%	Hammer	1.50	
Calcium silicate bricks KS as per EN 771-1 : 2011 + A1 : 2015	≥ 2.0	≥ 20	Vertically perforation up to 15%	Hammer	1.50	
Calcium silicate hollow block KSL as per EN 771-1 : 2011 + A1 : 2015 	≥ 1.6	≥ 12	Vertically perforation more than 15% and less than 50%, outer web thickness ≥ 20 mm	Hammer	1.50	
Vertically perforated clay bricks Porotherm 25 	≥ 0.8	≥ 15	Vertically perforation more than 15% and less than 50%, outer web thickness ≥ 12 mm	Rotary	1.20	
Vertically perforated ceramic block MAX 250 	≥ 0.8	≥ 15	Vertically perforation more than 15% and less than 50%, outer web thickness ≥ 12 mm	Rotary	1.20	

ANNEX C1

Performances / Characteristic resistance of ThermoDrive-V2 – part 2

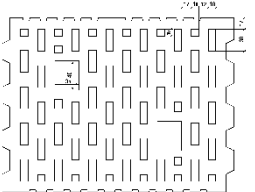
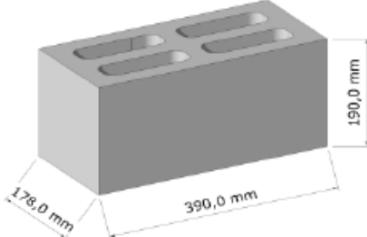
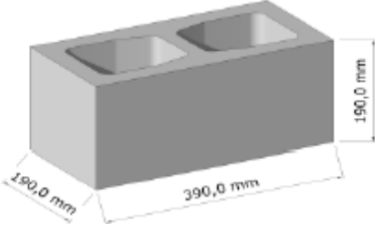
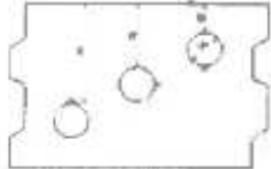
Table C1: Characteristic resistance to tension loads N_{Rk} in concrete and masonry for a single anchor in kN					
Anchor type					ThermoDrive-V2
Base materials	Bulk density ρ [kg/dm ³]	minimum compressive strength f_b [N/mm ²]	General remarks	Drill method	N_{Rk} [kN]
Vertically perforated clay bricks Hlz as per EN 771-1 : 2011 + A1 : 2015 	≥ 1.2	≥ 12	Vertically perforation more than 15% and less than 50%, outer web thickness ≥ 12 mm	Rotary	1.50
Tekno Amer Block PK17,8 	≥ 1.5	≥ 25	Exterior web thickness ≥ 30 mm	Rotary	1.50
Tekno Amer Block PK19 	≥ 1.1	≥ 20	Exterior web thickness ≥ 30 mm	Rotary	1.50
Lightweight concrete hollow blocks HBL as per EN 771-3 : 2011 + A1 : 2015 	≥ 0.8	≥ 2	Vertically perforation more than 15% and less than 50%, outer web thickness ≥ 30 mm	Rotary	1.50

ANNEX C3

Performances / Characteristic resistance of ThermoDrive-V2 – part 3

Table C1: Characteristic resistance to tension loads N_{Rk} in concrete and masonry for a single anchor in kN					
Anchor type				ThermoDrive-V2	
Base materials	Bulk density ρ [kg/dm ³]	minimum compressive strength f_b [N/mm ²]	General remarks	Drill method	N_{Rk} [kN]
Autoclaved concrete blocks as per EN 771-4 : 2011 + A1 : 2015	≥ 0.35	≥ 2		Rotary	1.20
Autoclaved concrete blocks as per EN 771-4 : 2011 + A1 : 2015	≥ 0.65	≥ 5		Rotary	1.50
Lightweight concrete blocks LAC as per EN 1520 : 2011 / EN 771-3 : 2011 + A1 : 2015	≥ 0.88	≥ 5		Rotary	1.20

ANNEX C4

Performances / Point thermal transmittance, plate stiffness, displacement

Table C2: Point thermal transmittance according to EOTA Technical Report TR 025

Anchor type	Insulation thickness h_D [mm]	Point thermal transmittance χ [W.K ⁻¹]
ThermoDrive-V2 surface mount	100	0.001
ThermoDrive-V2 surface mount	110 to 400	0.002
ThermoDrive-V2 surface mount	410 to 430	0.001
ThermoDrive-V2 immersed mount	100 to 450	0.001

Table C3: Plate stiffness according to EOTA Technical Report TR 026

Anchor type	Diameter of the anchor plate d_{plate} [mm]	Load resistance of the anchor plate $N_{u,m}$ [kN]	Plate stiffness $N_{0,m}$ [kN.mm ⁻¹]
ThermoDrive-V2	60	2.6	1.0

Table C4: Displacements ThermoDrive-V2

Base material (refer to Table C1)	Bulk density ρ [kg/dm ³]	Minimum compressive Strength f_b [N/mm ²]	Tension load N [kN]	Displacements $\Delta\delta_N$ [mm]
Concrete C12/15	≥ 2.2	≥ 20	0.5	0.44
Concrete C16/20 – C50/60	≥ 2.25	≥ 30	0.5	0.47
Thin concrete members (eg weather resistant skins) C16/20 – C50/60	≥ 2.0	≥ 20	0.5	0.47
Clay bricks MZ	≥ 2.0	≥ 20	0.5	0.68
Calcium silicate bricks KS	≥ 2.0	≥ 20	0.5	0.66
Calcium silicate hollow block KSL	≥ 1.6	≥ 12	0.5	0.53
Vertically perforated clay bricks Porotherm 25	≥ 0.8	≥ 15	0.4	0.64
Vertical perforated ceramic bricks MAX 250	≥ 0.8	≥ 15	0.4	0.68
Vertically perforated clay bricks HLZ	≥ 1.2	≥ 12	0.5	0.62
Tekno Amer Block PK17,8	≥ 1.5	≥ 25	0.5	0.58
Tekno Amer Block PK19	≥ 1.1	≥ 20	0.5	0.48
Lightweight concrete hollow blocks HBL	≥ 0.8	≥ 2	0.5	0.65
Autoclaved concrete blocks	≥ 0.35	≥ 2	0.4	0.68
Autoclaved concrete blocks	≥ 0.65	≥ 5	0.5	0.56
Lightweight concrete blocks LAC	≥ 0.88	≥ 5	0.4	0.44



British Board of Agrément,
1st Floor Building 3,
Hatters Lane,
Croxley Park
Watford
WD18 8YG