

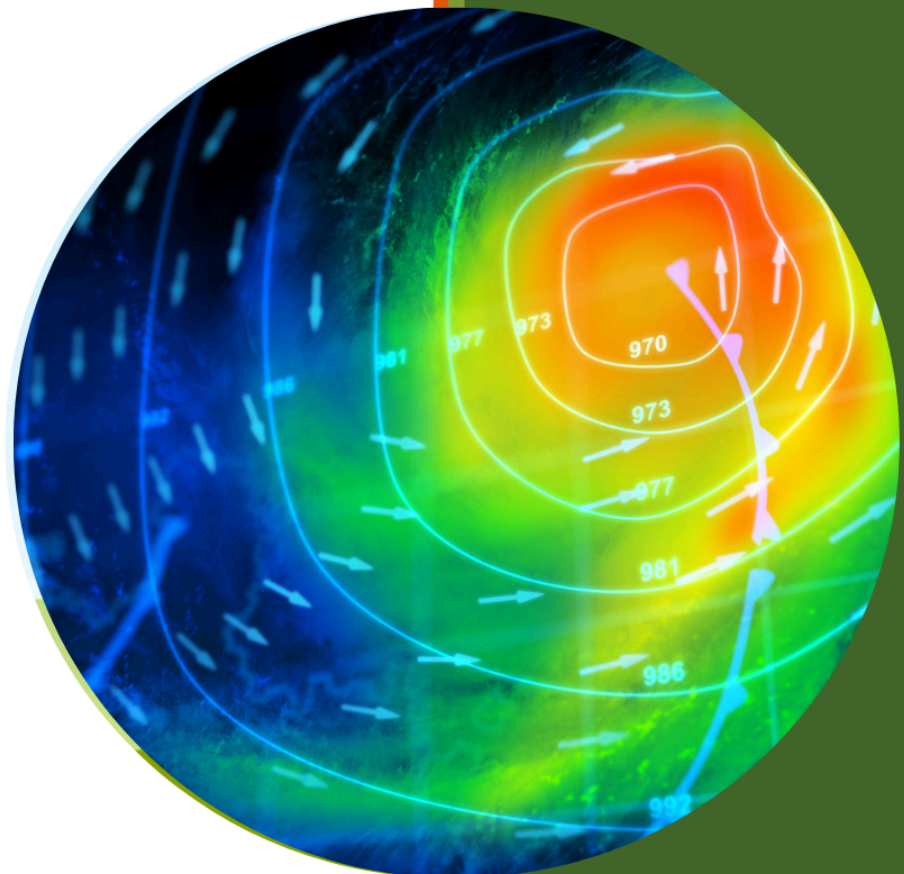

LEADING THE UK EWI INDUSTRY

INCA Technical Guidance Document 06

EWI Specification: Weathering & Thermal Bridge Control



*External wall
insulation
specification for
weathering and
thermal bridge
control* — *Guide. May 2019*

Specification for Weathering and Thermal Bridge Control

Foreword

The installation of external wall insulation (EWI) to improve the thermal performance and efficiency of residential and non-residential building has become widespread and is well established in the UK, with many installations over 30 years old, and the approach is recognised as being able to bring significant reductions in heat loss to the walls of buildings as well as contributing to a reduction in CO₂ emissions.

In order for optimum performance to be achieved, external wall insulation systems (a form of so-called 'solid wall' insulation, SWI) should be designed and installed to have good continuity of the insulation with few thermal bridges, and should be detailed to ensure that water penetration from the external environment is prevented so that the insulation layer remains dry, and so that problems associated with water collection in the building fabric do not occur.

This Specification for Weathering and Thermal Bridge Control comprises of a set of design details which have been prepared for use by practitioners of external wall insulation, including Retrofit Designers, Architects, and installers.

The details provided are not exhaustive, but set out the general principles involved to ensure that installed EWI systems address issues of thermal bridging and weather tightness. The details provide guidance only, and are intended to assist designers and other practitioners to differentiate between details which might result in thermal bridging and/or risk of failure due to weather penetration.

The Thermal Bridging elements of these details have evolved from the details provided in support of PAS2030:2017, and have been extended to include guidance on providing weathering resistance.

Those thermal bridging details that are green coded provide a managed control of thermal bridging, whilst those coded as amber have an increased risk of condensation and mould growth associated with them if internal conditions - in terms of ventilation and temperature - are unfavourable. On some wall constructions these amber-coded details may pose no risk but this would need to be proven by the additional undertaking of thermal bridging modelling or by otherwise ensuring that internal humidity levels and ventilation conditions are such that the condensation risk is adequately reduced for the lifetime of the measure.

In all cases, practitioners must make every reasonable endeavour to ensure that thermal bridge free detailing is adopted and should demonstrate that, where green-coded details are not employed, every effort is made to incorporate details that come as close to the green-coded detail as is practicably possible, and the amber-coded details are deemed to satisfy this requirement.

The long term weathering resistance of an installed EWI system is dependent not only on the type and quality of the materials of the system, but also on the detailing and quality of installation.

Effective prevention of water penetration (i.e. weathering resistance) can be achieved by considering the EWI system details, identifying possible modes of failure ('Risks') which would result in water penetration, and providing guidance on how the risks can be reduced or eliminated altogether ('Solutions').

The guidance in this document considers a range of typical construction elements which may be found on most retrofit installation projects and identifies the potential risks as far as weathering are concerned. In each instance, one or more approaches are offered which, if followed, will provide a long lasting and durable weather resistant detail.

In some cases, works to other building elements may be required in order to provide an optimised detail - these can be considered to be 'best practice'. In other cases it is understood that best practice may not be achieved for technical reasons or for reasons of practicability. In these cases, the details provided identify the risks associated with employing a less robust detail. *Building owners and practitioners should be advised that failure to adopt best practice guidance at an early stage may result in higher costs as a result of problems caused by taking an easier route at an early stage.*

Although other details will invariably arise on individual projects and which are not covered within this document, the same underlying principles apply insofar as it is possible to design and install an EWI system that is entirely weather tight and which will provide a satisfactory level of performance for the lifetime of the building onto which it is applied, taking into account necessary inspection and maintenance cycles.

Pre-installation Surveys

Prior to preparing a specification for the installation of EWI on a building it is essential that a detailed survey of the property is carried out by a competent person. Poor assessment of the baseline condition of the building structure can cause problems, or lead to the aggravation of pre-existing conditions and may result in an inappropriate specification for the EWI system being issued.

The survey, which should be completed before the specification is issued should include all of the following:

- The building location
- The relationship of the building being treated with that of adjoining buildings which are to remain untreated.
- Exposure zone for wind driven rain - reference can be made to BRE publication BR 262 'Thermal Insulation: Avoiding Risks'
- Potential sites of thermal bridging - reference can be made to BRE publication FB61 'Reducing thermal bridging at junctions when designing and installing solid wall insulation'
- Proximity to sources of air-borne pollution (e.g. heavy vehicular or rail freight traffic)
- The state of repair of the wall and other related elements (including drainage)
- Sources of moisture (incidences of rising or penetrating damp)
- Ventilation
- Heritage
- Identification of any defects that should be addressed before installation works begin
- Restrictions or obstacles to the installation
- The number, nature, location and identification of all fuel burning appliances (in accordance with the guidance set out in NIA/HHIC publication 'Specification for the installation of external wall insulation ensuring the safety and operation of fuel burning appliances V.1.0 31st March 2017')

The information collected during the survey will inform the EWI system specification and design which should include all interface, edge and abutment details for which a weathering-critical solution is required, and details which address all potential thermal bridging sites.

Appropriate weathering and thermal bridging control details should then be provided to the installation teams to ensure that the system is installed to achieve optimum performance. Appropriate checks and inspections should be carried out during the installation, and after its completion, to ensure that all of the details have been installed correctly and that the system is appropriately sealed, all in accordance with the details and specification.

No installation work should be undertaken until all of the specified information has been obtained and confirmed.

Installation Operatives / Technicians

To attain a level of competence, EWI technicians/installation operatives must have successfully completed a training course covering all matters referred to in this guide. Trained operatives and their supervisors must be able to demonstrate that they are able to read and understand the detail drawings so that the details supplied by the EEM designer, Architect and/or EWI system designer can be correctly constructed on site.

EWI installation operatives should not undertake works associated with combustion fuel appliances. Works such as removal and re-instatement of condensate drains, modification to pressure relief valve (PRV) discharge pipes etc., may be carried out by another competent person such as a plumber, but if any doubt exists then a Gas Safe registered engineer or other competent person should be consulted.

Legal Requirements

The main legal requirements for protection of the public and employees are the general provisions of the Health and Safety at Work Act 1974, and related legislation, including the Management of Health and Safety at Work Regulations 1999.

These require the drawing up of a 'risk assessment' and plan of protective measures, as well as the appointment of competent persons to ensure that safety requirements are met effectively.

Responsibilities of EWI/SWI System Installers

Where inadequate design and/or installation occurs EWI systems are more vulnerable to installation defects such as poor water tightness, which can lead to the insulation becoming waterlogged or even to water entry into the building, or thermal bridging which can result in dampness and mould growth on internal surfaces.

EWI installers have the responsibility for ensuring that upon completion of the EWI/SWI installation the system is adequately sealed, robust, thermal- and weather-tight. Installers must leave flues, chimneys, combustion air ventilators, and any other items relating to the safe operation of gas appliances in the same (or better) condition than before the EWI installation took place.

Furthermore, if during EWI installation work, faults are identified which could harm the occupants or installation operatives, or if any gas pipework is damaged or disturbed, appropriate action must be taken to safeguard people's health and well-being: Seek immediate advice from a Gas Safe registered engineer and/or contact the Gas Emergency Service.

Sealants

In this guidance the use of sealants (mastics, caulking) as the sole means of providing a weather tight seal between an exterior rendered surface and its abutment to another material is not accepted, in line with PAS rules. In all cases, sealants should only be used in conjunction with an appropriate backing material, such as a compressed hydrophobic tape or proprietary backing rod.

Where sealants are employed to provide a barrier to water penetration (e.g. at service penetrations, etc.) the choice of sealant type must take into account the varying movement capabilities of the sealant material, its UV resistance, adhesion properties, and its compatibility with the materials of the surfaces against which it will be applied. The use of the wrong sealant type for a particular application can result in failure regardless of other factors, and failure can contribute to water penetration at the joint. In all cases where sealants are employed as an outer /external seal, a suitable backing rod or tape must be employed in addition to the sealant.

Sealants should be as specified by the EWI system supplier to ensure compatibility with the render system. Where no recommendation is made by the EWI system supplier guidance on the selection of an appropriate sealant can be found in BS 6213. Sealants should generally be low-modulus elastic types since these are more suitable where constant movement is likely. The long term performance of the sealant should be confirmed by the manufacturer.

Sealing Tapes

Sealing tapes are pre-compressed, expanding foam tapes that are used to provide a permanently elastic weather seals at junctions and abutments. They usually have a self-adhesive backing which makes installation quick, easy and clean and they can be used to seal against the contours of irregular or uneven surfaces. Being permanently elastic, sealing tapes allow for continual expansion and contraction and when fitted under compression, sealing tapes are fully weather resistant and can protect against wind-driven rain.

Sealing tapes can be hydrophobic/water repellent, although the hydrophobic quality of the material is less of a consideration than whether it is an open cell or closed cell foam. Only closed cell foam sealing tapes should be used for weather protection applications - the closed cell structure provides better water sealing properties.

Where joining of adjacent lengths of sealing tape is required to provide a continuous seal, the ends of the tapes should be neatly cut and the ends should be overlapped by about 25 mm. Butted joints should not be used.

Beads, Trims, Flashings

The weathering resistance of beads trims and flashings will depend on the type of material and the conditions that the material is exposed to.

Exposure to sunlight / UV

Metals for trims and flashings are usually aluminium alloy or stainless steel, both of which are unaffected by UV exposure. However, the coatings applied to metals (e.g. polyester powder coatings) will suffer a loss of colour and gloss as a result of prolonged UV exposure.

PVC components that are exposed to sunlight will, to a lesser or greater extent (depending on the purity of the PVC and the presence or absence of UV-absorbing additives) exhibit some surface chalking and discoloration for as long as the exposure persists. Prolonged exposure will also cause the material to lose some of its resistance to impact - the material may become weak and brittle.

Effect of temperature changes

All materials expand and contract with changes in temperature, but PVC has a higher coefficient of linear thermal expansion than that of aluminium or stainless steel. Large, unreinforced, PVC components, such as oversills, will expand and contract more than similar components fabricated from aluminium or stainless steel.

It is important that EWI system abutments to metal and PVC components (e.g. window sills, window frames, oversills, etc.) include flexible, elastic, weather seals, such as compressible tapes, to ensure that weather resistance is maintained even as the PVC or metal expands or contracts due to temperature changes.

In the case of PVCu components, which tend to be much thicker than their metal counterparts, temperature differences across the thickness can also result in significant bowing, so the use of PVC-U components in exposed locations should be considered with care, and sealing tapes should be sized to accommodate the greater degree of movement that PCVu components are likely to exhibit.

Note: For clarity and to avoid duplication, details for working around flue penetrations and other fuel burning appliances and associated fixtures and fittings have been omitted. Reference should be made to the following document for guidance in relation to these areas:

Specification for the installation of external wall insulation ensuring the safety and operation of fuel burning appliances.

SPECIFICATION FOR WEATHERING AND THERMAL BRIDGE CONTROL

THERMAL BRIDGING RISK LEVEL

Note :

- All details indicate fixings that are thermally broken.
- Detail can only be adopted where ground conditions allow. If the ground is a hard surface, pathway or if existing drainage will be disturbed the detail can be difficult to achieve and not practicably possible.
- Detail not allowed where frame thickness allows for reveal insulation



Green, no effect on risk level.

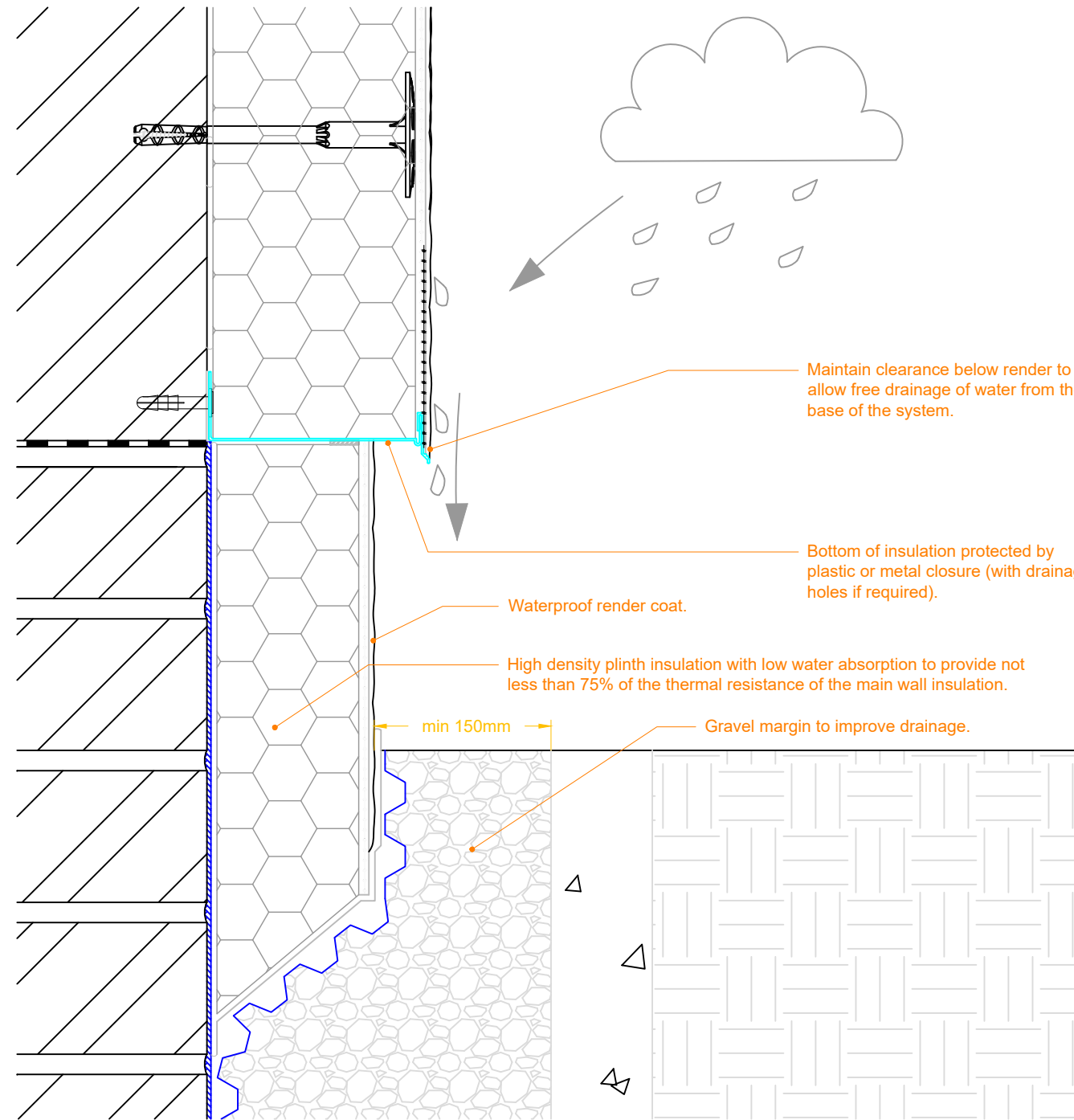

WEATHERING RISK

Risks: Inadequate free drainage of water from the bottom of the render prevents render surface from drying.

Solutions:

- Maintain a clear gap between the bottom edge of the render and the surface below. Bottom of the system protected by a plastic (low thermal conductivity) or metal starter track/base track.

Title:	Insulated Plinth
Dwg. No.	WRD-B001
Rev.	-
Date:	18/12/2018

SPECIFICATION FOR WEATHERING AND THERMAL BRIDGE CONTROL

THERMAL BRIDGING RISK LEVEL

Note :

- All details indicate fixings that are thermally broken.



Green if insulation has same thickness or same thermal resistance as main wall insulation.



Amber if insulation has a thickness or thermal resistance of at least 75% of main wall insulation. Note that amber will increase the assessed inherent technical risk level in table B2 of PAS 2035 by 1

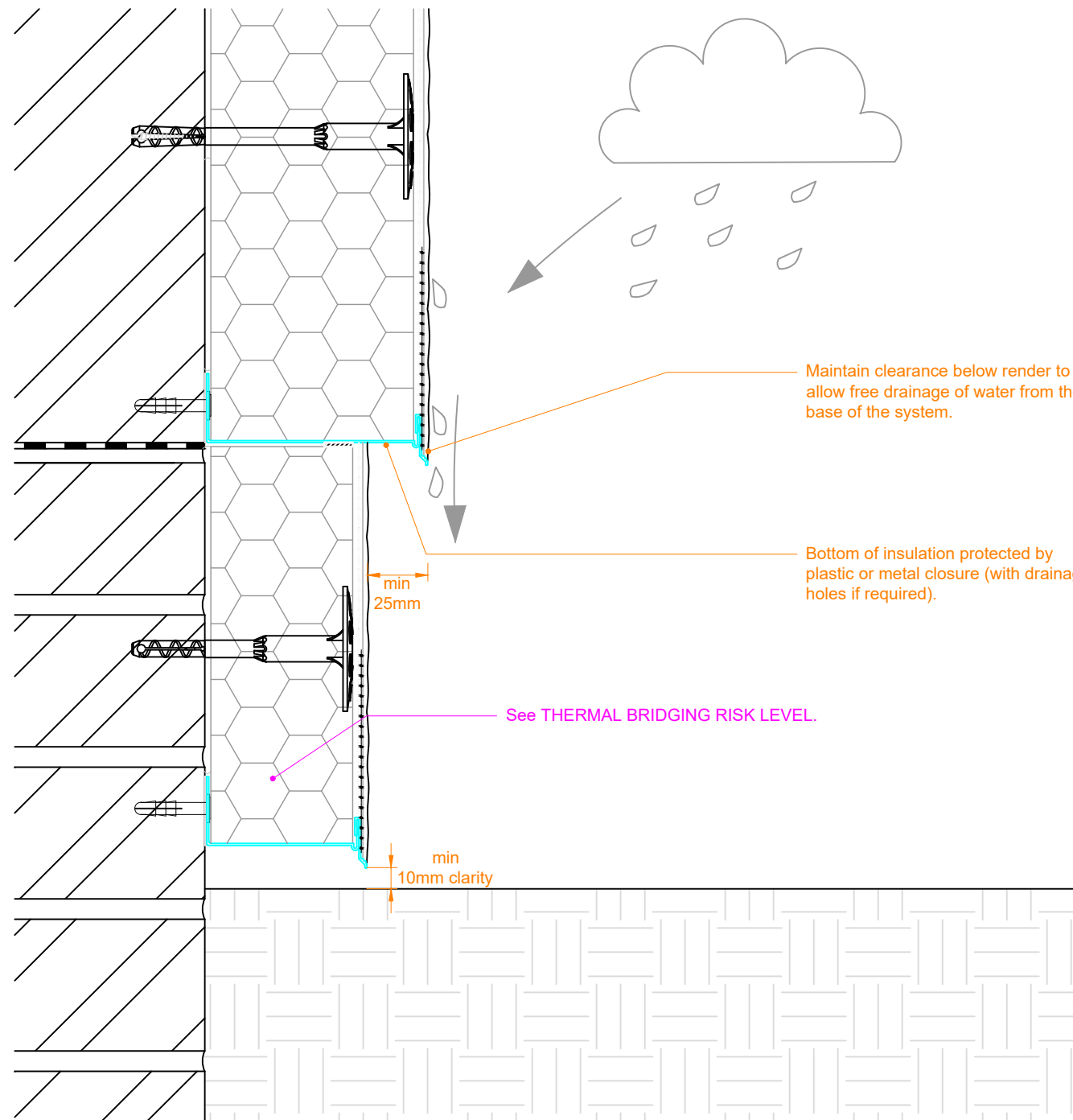

WEATHERING RISK

Risks: Inadequate free drainage of water from the bottom of the render prevents render surface from drying.

Solutions:

- Maintain a clear gap between the bottom edge of the render and the surface below. Bottom of the system protected by a plastic (low thermal conductivity) or metal starter track/base track.

Title:	Partially-insulated Plinth
Dwg. No.	WRD-B002
Rev.	-
Date:	18/12/2018

SPECIFICATION FOR WEATHERING AND THERMAL BRIDGE CONTROL

THERMAL BRIDGING RISK LEVEL

● Green, no effect on risk level.

Captions :

- ① Insulation should have a thermal resistance of not less than 0.6 m²K/W. Common practice is to over sail the main insulation board past the reveal by 20 mm and adhesively fix the reveal insulation within the remaining recess.

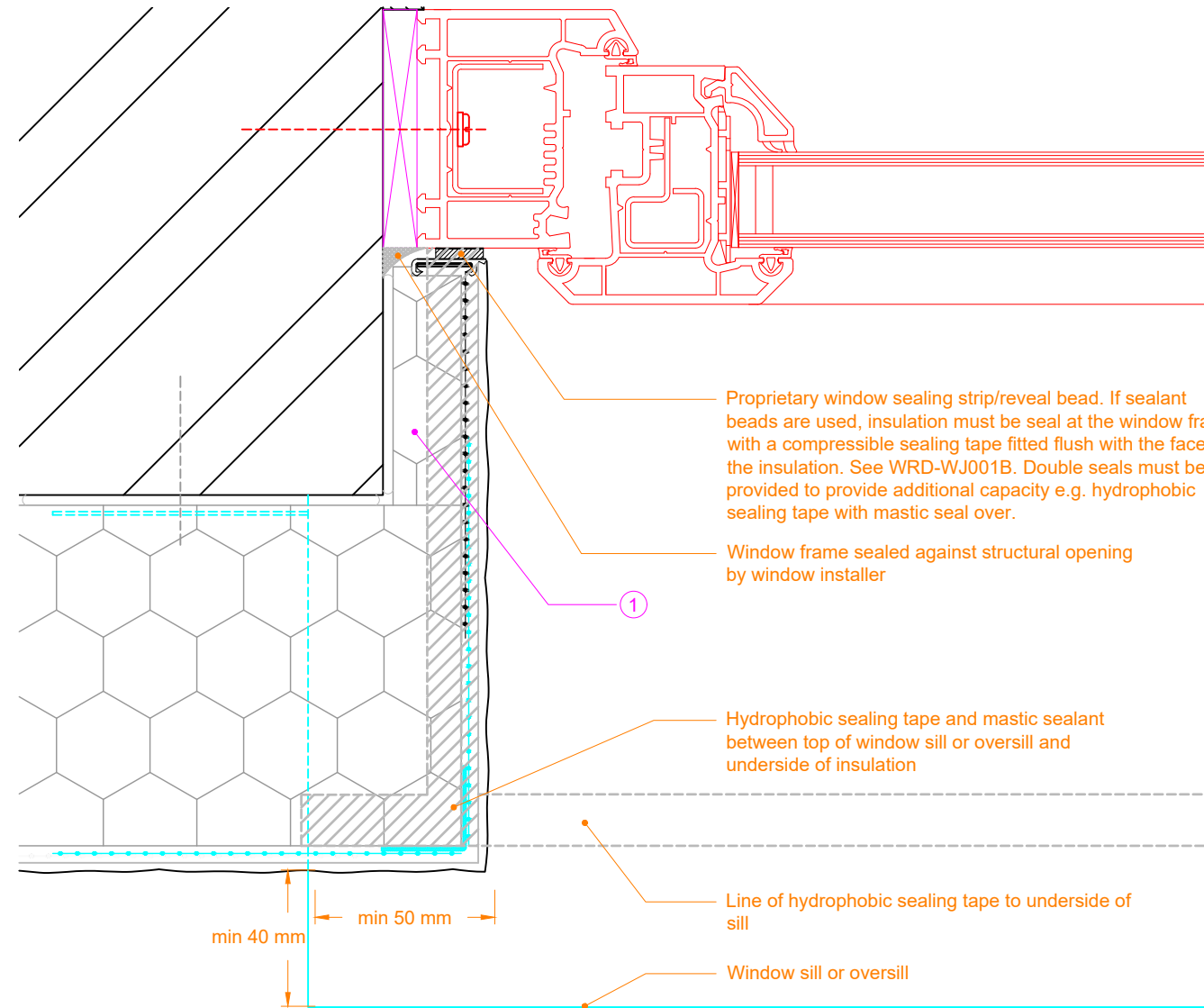

WEATHERING RISK

Risks: Water penetration into EWI system or building at window reveal.

Solutions:

- Windows frame sealed against structural opening and weathertight prior to installation of the EWI system.
- EWI system sealed against window frame at jamb using proprietary window sealing strip/reveals bead.
- EWI sealed against window sill/oversill with fully compressed hydrophobic sealing tape and mastic sealant.
- Designers should consider the use of sills with greater projection where exposure is Zone 4/very severe (BR262).

Title:	Insulation to Recessed Reveal - with Proprietary Window Sealing Strip/Reveals Bead
Dwg. No.	WRD-WJ001A
Rev.	-
Date:	18/12/2018

THERMAL BRIDGING RISK LEVEL

● Green, no effect on risk level.

Captions :

- ① Insulation should have a thermal resistance of not less than 0.6 m²K/W. Common practice is to over sail the main insulation board past the reveal by 20 mm and adhesively fix the reveal insulation within the remaining recess.

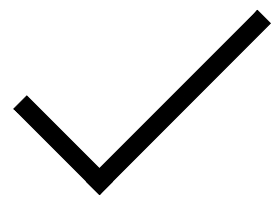
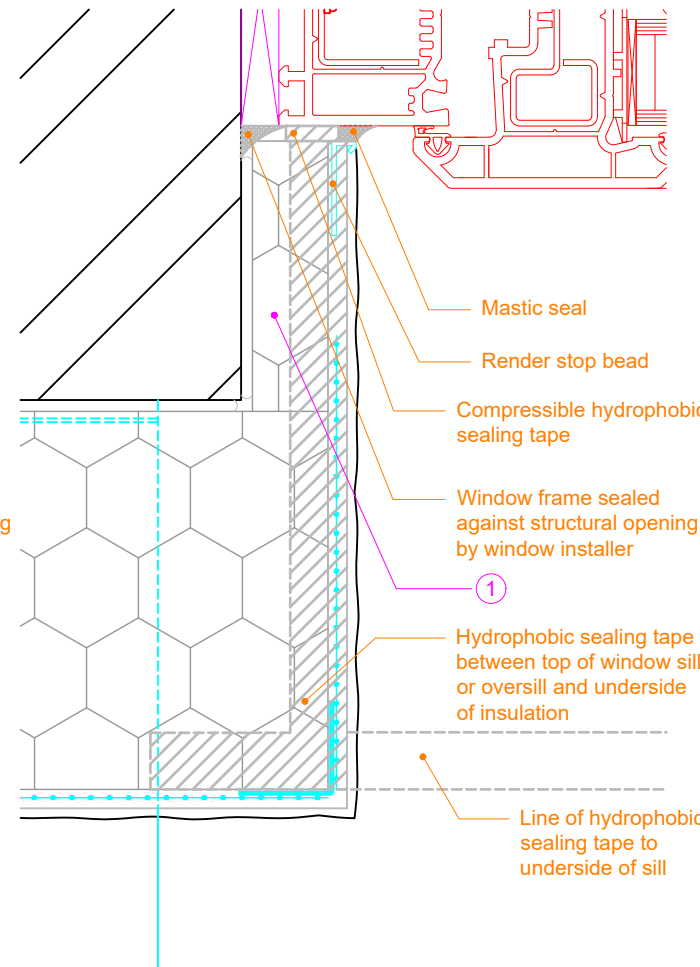
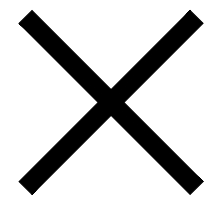
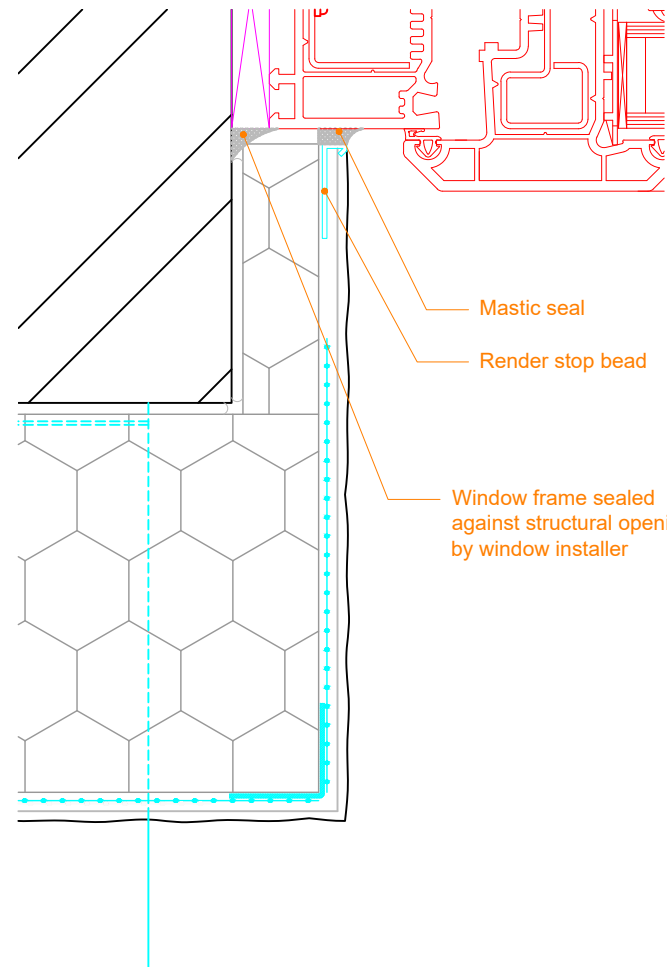

WEATHERING RISK

Risks: Water penetration into EWI system or building at window reveal.

Solutions:

- Windows frame sealed against structural opening and weathertight prior to installation of the EWI system.
- EWI system sealed against window frame at jamb using proprietary window sealing strip/reveals bead.
- EWI sealed against window sill/oversill with fully compressed hydrophobic sealing tape and mastic sealant.

TITLE:	Insulation to Recessed Reveal - with Render Stop Bead and Mastic Seal
Dwg. No.	WRD-WJ001B
Rev.	-
Date:	18/12/2018

THERMAL BRIDGING RISK LEVEL

Note :

- All details indicate fixings that are thermally broken.



Green, no effect on risk level.

Captions :

- ① Insulation should have a thermal resistance of not less than 0.6 m²K/W. Common practice is to over sail the main insulation board past the reveal by 20 mm and adhesively fix the reveal insulation within the remaining recess.

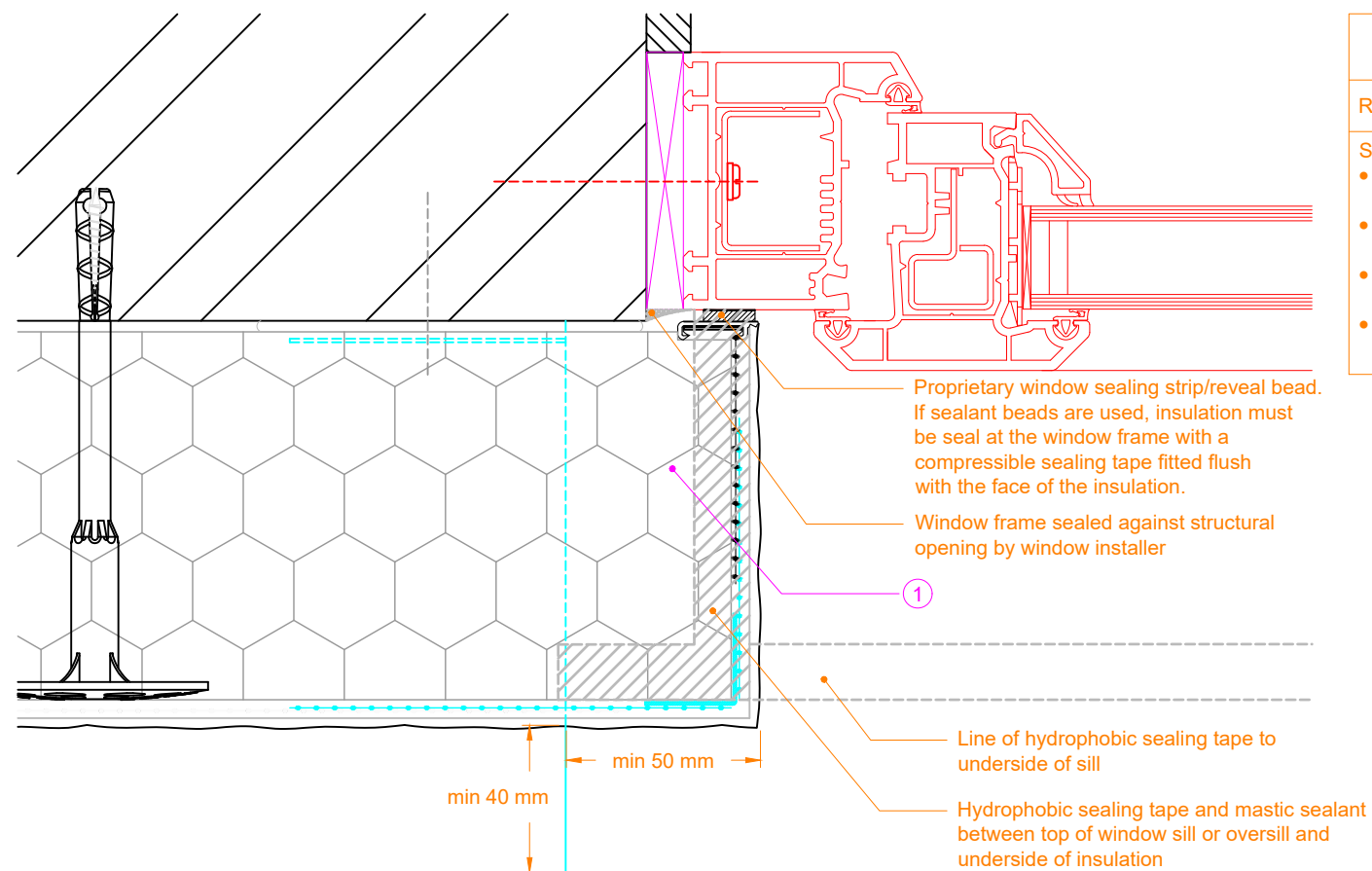

WEATHERING RISK

Risks: Water penetration into EWI system or building at window reveal.

Solutions:

- Windows frame sealed against structural opening and weathertight prior to installation of the EWI system.
- EWI system sealed against window frame at jamb using proprietary window sealing strip/reveals bead.
- EWI sealed against window sill/oversill with fully compressed hydrophobic sealing tape and mastic sealant.
- Designers should consider the use of sills with greater projection where exposure is Zone 4/very severe (BR262).

TITLE:	Insulation over Flush Reveal - with Proprietary Window Sealing Strip/Reveals Bead
Dwg. No.	WRD-WJ002
Rev.	-
Date:	18/12/2018

SPECIFICATION FOR WEATHERING AND THERMAL BRIDGE CONTROL

THERMAL BRIDGING RISK LEVEL

Note :

- All details indicate fixings that are thermally broken.
- Detail not allowed where frame thickness allows for reveal insulation



Amber if wall constructed in ≥ 225 mm solid brick. Not suitable for random stone constructions. Note that amber will increase the assessed inherent technical risk level in table B2 of PAS 2035 by 1.

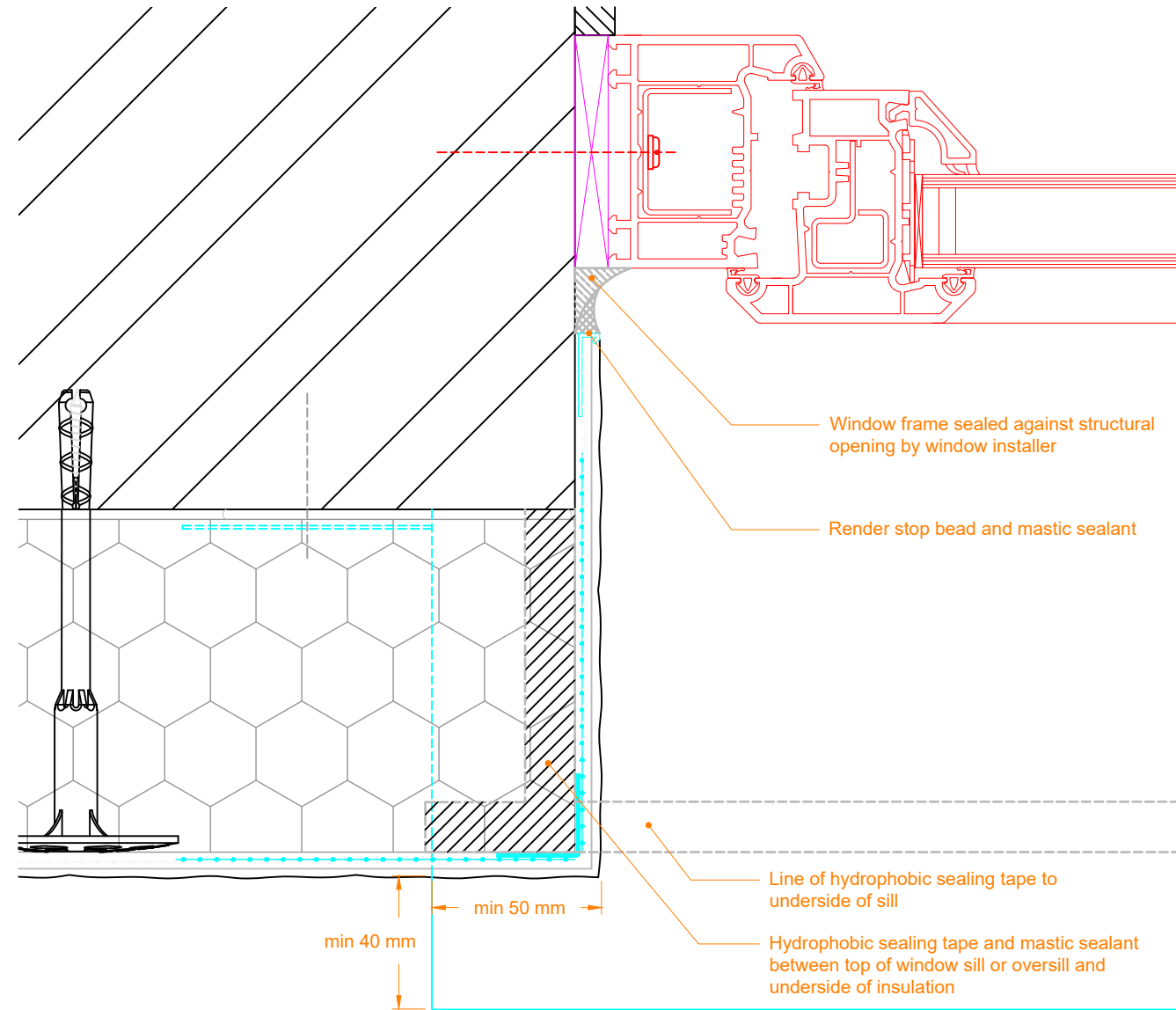

WEATHERING RISK

Risks: Water penetration into EWI system or building at window reveal.

Solutions:

- Windows frame sealed against structural opening and weathertight prior to installation of the EWI system.
- EWI system sealed against window frame at jamb using proprietary window sealing strip/reveals bead.
- EWI sealed against window sill/oversill with fully compressed hydrophobic sealing tape and mastic sealant.
- Designers should consider the use of sills with greater projection where exposure is Zone 4/very severe (BR262).

Title:	Un-Insulated Reveal at Jamb
Dwg. No.	WRD-WJ003
Rev.	-
Date:	18/12/2018

THERMAL BRIDGING RISK LEVEL

Note :

- All details indicate fixings that are thermally broken.



Green, no effect on risk level.

Captions :

- ① Window frame and sill to be thermally broken.

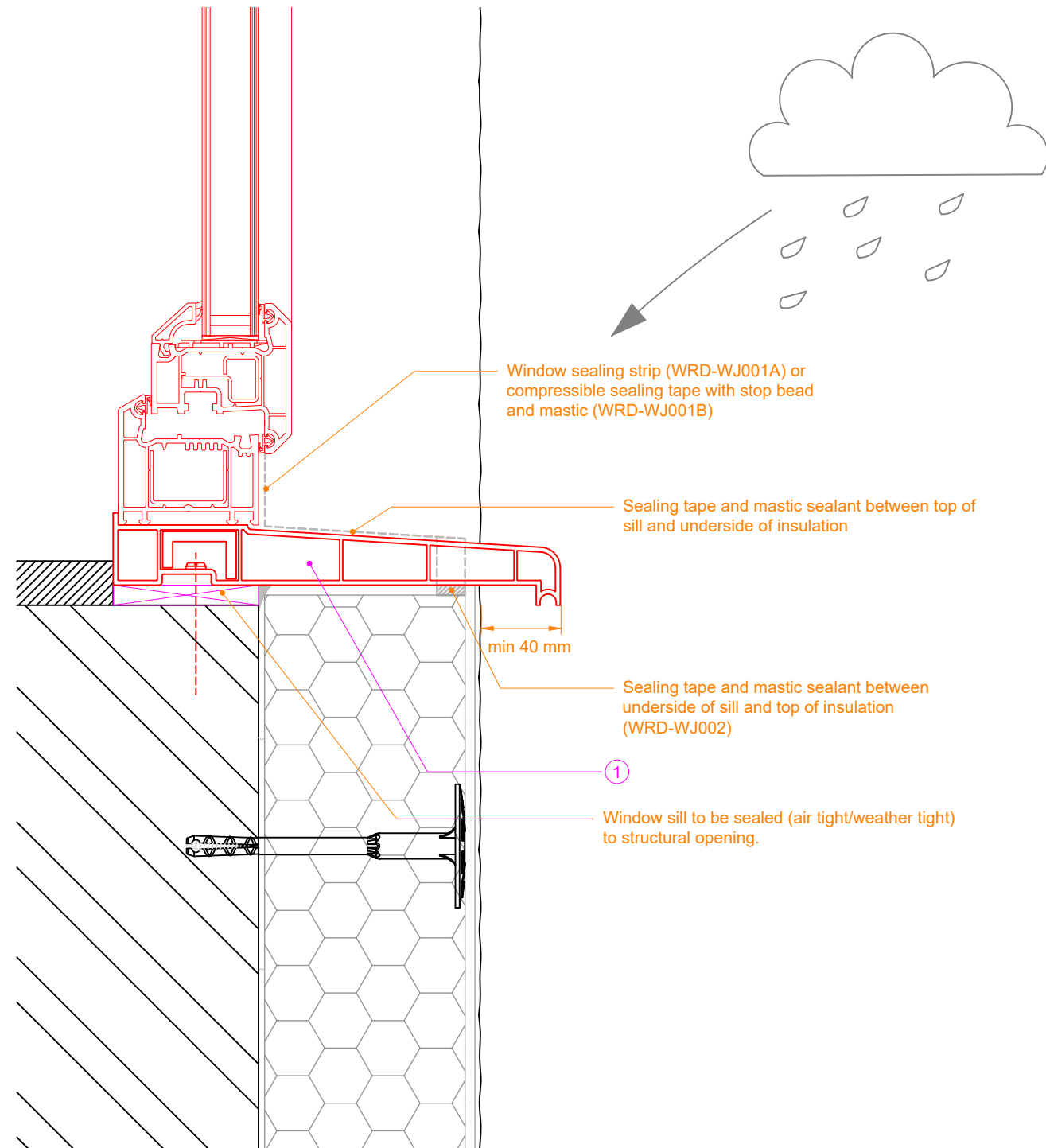

WEATHERING RISK

Risks:

- Window sill projection insufficient to provide effective water shedding.
- Differential thermal movement at render abutment to sill may allow water ingress.

Solutions:

- Windows sill and frame sealed against structural opening and weathertight prior to installation of the EWI system.
- EWI system sealed against window sill/oversill with fully compressed hydrophobic sealing tape and mastic sealant.
- Window sill to provide min 40 mm projection from face of render. *
- If window sill projection is insufficient, provide suitable over- or under-sill (see WRD-WS003).
- Designers should consider the use of sills with greater projection where exposure is Zone 4/very severe (BR262).

* See BSEN13914-1:2016 Design, preparation and application of external rendering and internal plastering. External rendering.

TITLE:	New Window with Extended Sill
Dwg. No.	WRD-WS001
Rev.	-
Date:	18/12/2018

SPECIFICATION FOR WEATHERING AND THERMAL BRIDGE CONTROL

THERMAL BRIDGING RISK LEVEL

Note :

- All details indicate fixings that are thermally broken.



Green, no effect on risk level.



Amber if non-thermally broken sill. Note that amber will increase the assessed inherent technical risk level in table B2 of PAS 2035 by 1.

Captions :

- ① Window frame and sill to be thermally broken. All sills should have end caps and be fixed using either mechanical fixings with plastic caps or high strength adhesives.

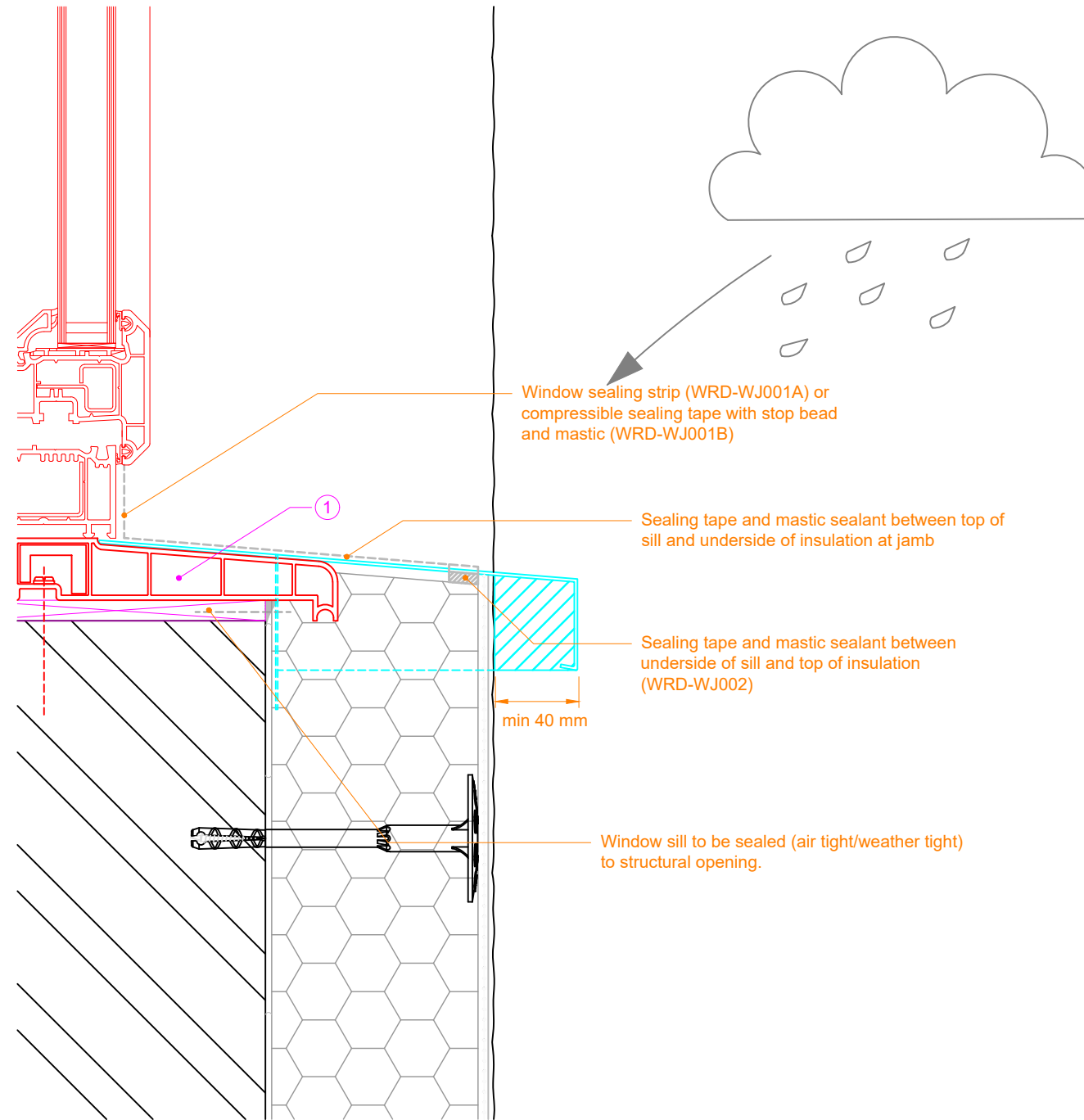

WEATHERING RISK

Risks:

- Window sill projection insufficient to provide effective water shedding.
- Differential thermal movement at render abutment to sill may allow water ingress.

Solutions:

- Windows sill and frame sealed against structural opening and weathertight prior to installation of the EWI system.
- EWI system sealed against window sill/oversill with fully compressed hydrophobic sealing tape and mastic sealant.
- Window sill to provide min 40 mm projection from face of render.*
- If window sill projection is insufficient, provide suitable over- or under-sill (see WRD-WS003) with min. 40 mm projection.
- Designers should consider the use of sills with greater projection (50 mm) where exposure is Zone 4/very severe (BR262).
- System should be sealed against the frame by means of a hydrophobic tape and mastic or proprietary stop bead with integral hydrophobic tape.
- Ensure that any existing drainage holes are not blocked, or install new drainage holes.

* See BSEN13914-1:2016 Design, preparation and application of external rendering and internal plastering. External rendering.

Title:	Existing Window with Oversill
Dwg. No.	WRD-WS002
Rev.	-
Date:	18/12/2018

SPECIFICATION FOR WEATHERING AND THERMAL BRIDGE CONTROL

THERMAL BRIDGING RISK LEVEL

See WRD-WS002

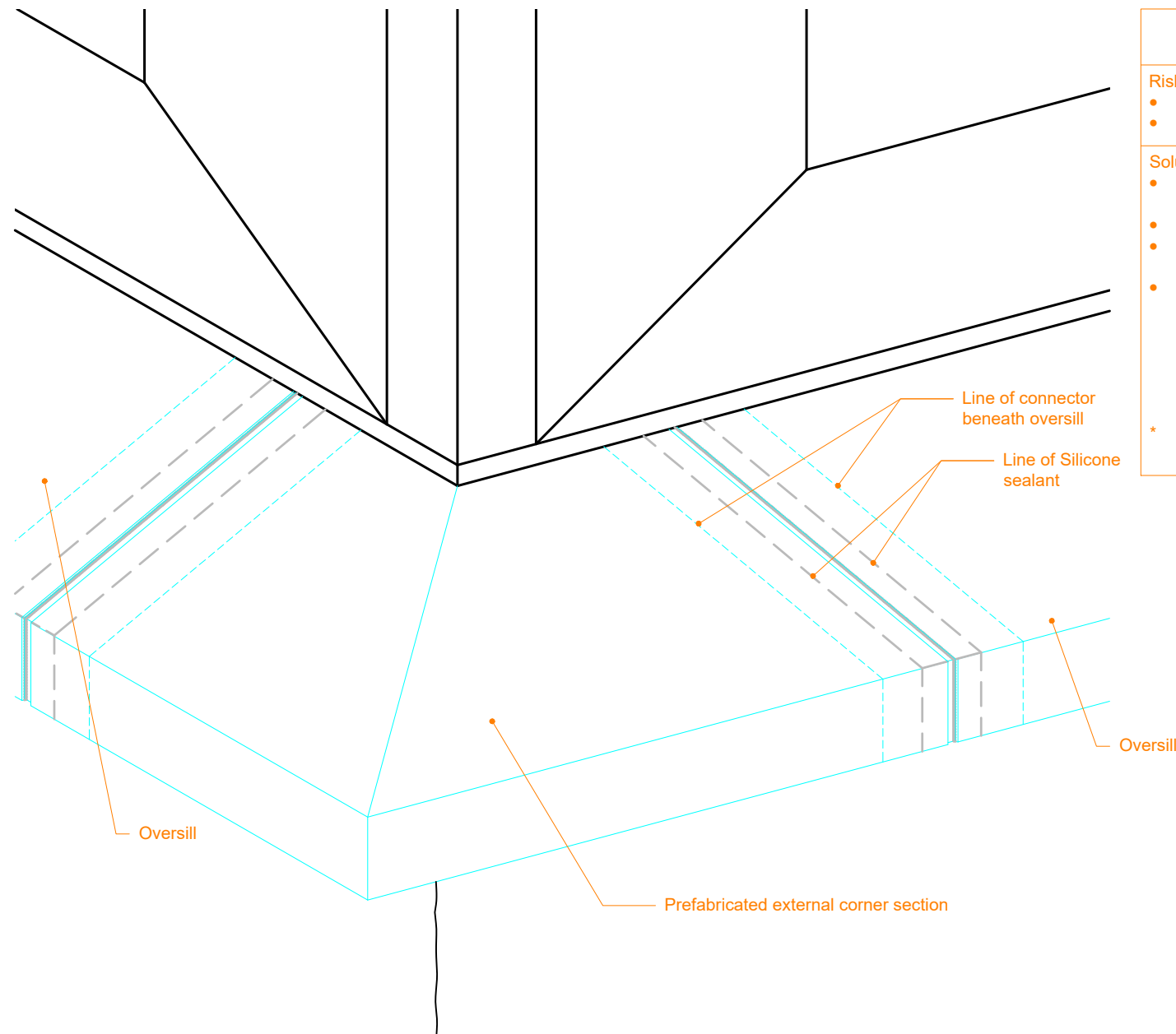

WEATHERING RISK

Risks:

- Window sill projection insufficient to provide effective water shedding.
- Water penetration at unsealed joint.

Solutions:

- Windows sill and frame sealed against structural opening and weathertight prior to installation of the EWl system.
- Oversill to provide min 40 mm projection from face of render.*
- Designers should consider the use of sills with greater projection (50 mm) where exposure is Zone 4/very severe (BR262).
- Adjacent sill sections joined together with metal connectors with seals on both sides of the joint.

* See BSEN13914-1:2016 Design, preparation and application of external rendering and internal plastering. External rendering.

TITLE:	Oversill External Corner : Polyester Powder Coated Aluminium
Dwg. No.	WRD-WS003
Rev.	-
Date:	18/12/2018

SPECIFICATION FOR WEATHERING AND THERMAL BRIDGE CONTROL

THERMAL BRIDGING RISK LEVEL

Note :

- All details indicate fixings that are thermally broken.



Green, no effect on risk level.



Amber if non-thermally broken sill. Note that amber will increase the assessed inherent technical risk level in table B2 of PAS 2035 by 1.

Captions :

- ① Window frame and sill to be thermally broken.

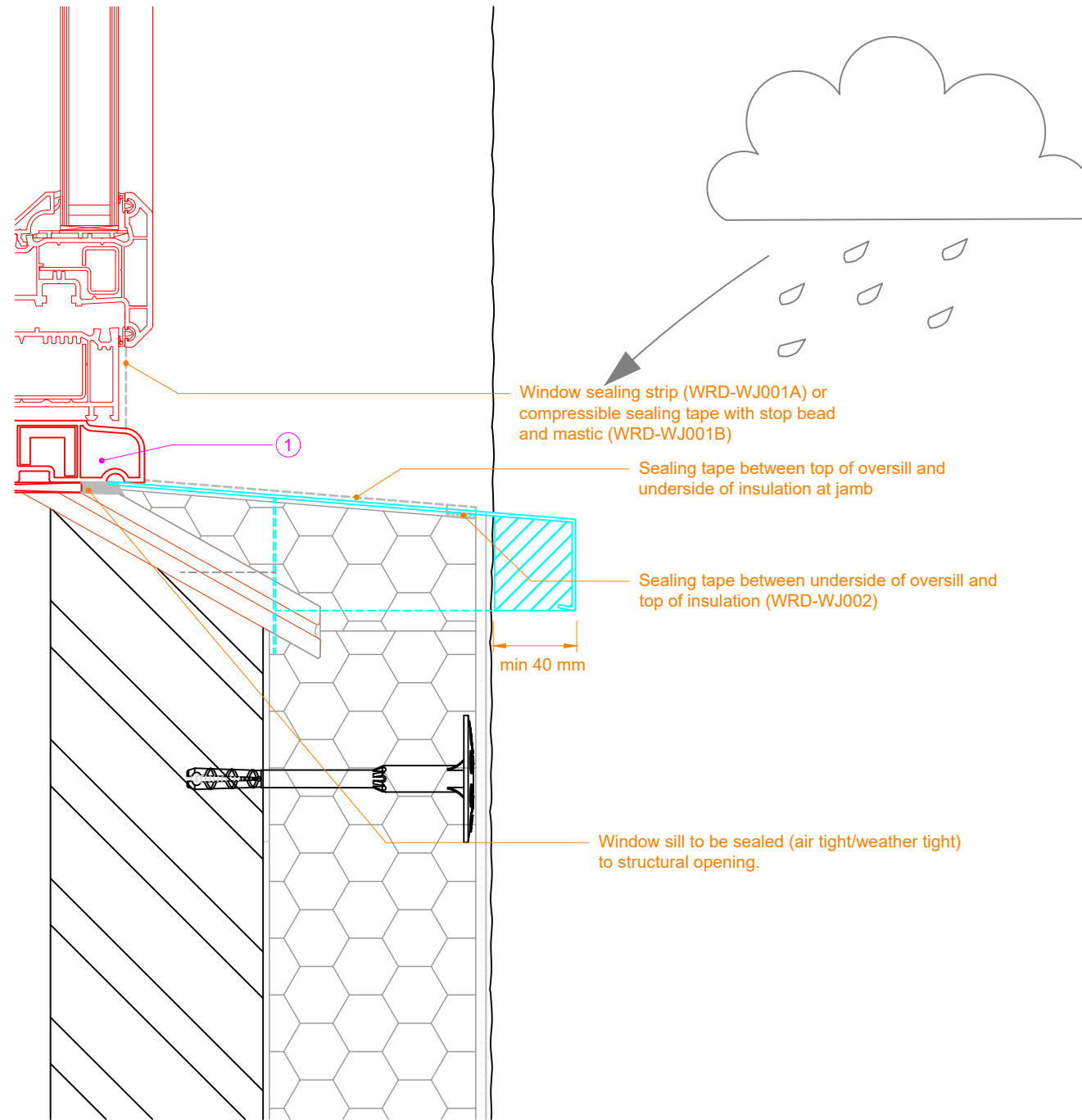

WEATHERING RISK

Risks:

- Window sill projection insufficient to provide effective water shedding.
- Differential thermal movement at render abutment to sill may allow water ingress.

Solutions:

- Windows sill and frame sealed against structural opening and weathertight prior to installation of the EWI system.
- EWI system sealed against window sill/oversill with fully compressed hydrophobic sealing tape and mastic sealant.
- Ensure that any existing drainage holes are not blocked, or install new drainage holes.
- Oversill to provide min 40 mm projection from face of render.*
- Designers should consider the use of sills with greater projection (50 mm) where exposure is Zone 4/very severe (BR262).

* See BSEN13914-1:2016 Design, preparation and application of external rendering and internal plastering. External rendering.

TITLE:	Existing Window with Tile Sill and Oversill
Dwg. No.	WRD-WS004
Rev.	-
Date:	18/12/2018

THERMAL BRIDGING RISK LEVEL

Note :

- All details indicate fixings that are thermally broken.



Green, no effect on risk level.

Captions :

- ① Insulation should have a thermal resistance of not less than 0.6 m²K/W. Common practice is to over sail the main insulation board past the reveal by 20 mm and adhesively fix the reveal insulation within the remaining recess.

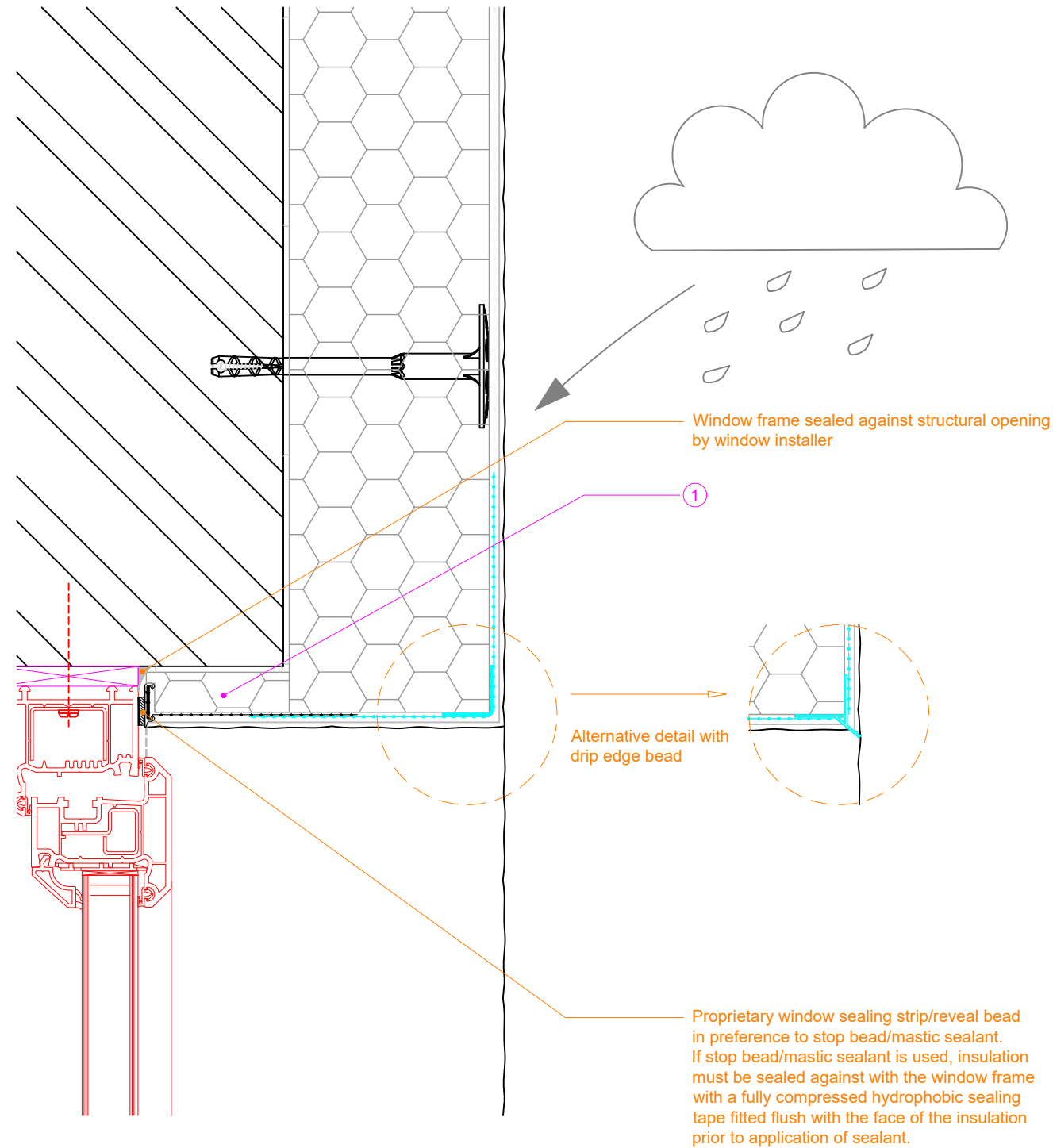

WEATHERING RISK

Risks: Water back-tracking to window frame.

Solutions:

- Windows frame sealed against structural opening and weathertight prior to installation of the EWI system.
- EWI system sealed against window frame at head using proprietary window sealing strip/reveals bead or sealing tape, stop bead and low-modulus sealant (see WRD-WJ001B).
- Drip edge corner bead at arris in lieu of standard corner bead to provide improved water shedding at render return into reveal at head.

TITLE:	Insulation to Recessed Head
Dwg. No.	WRD-WH001
Rev.	-
Date:	18/12/2018

SPECIFICATION FOR WEATHERING AND THERMAL BRIDGE CONTROL

THERMAL BRIDGING RISK LEVEL

Note :

- All details indicate fixings that are thermally broken.



Green, no effect on risk level.

Captions :

- ① Ensure specified insulation is taken over the window frame by 15 - 20 mm.
- ② Window to be thermally broken frame.

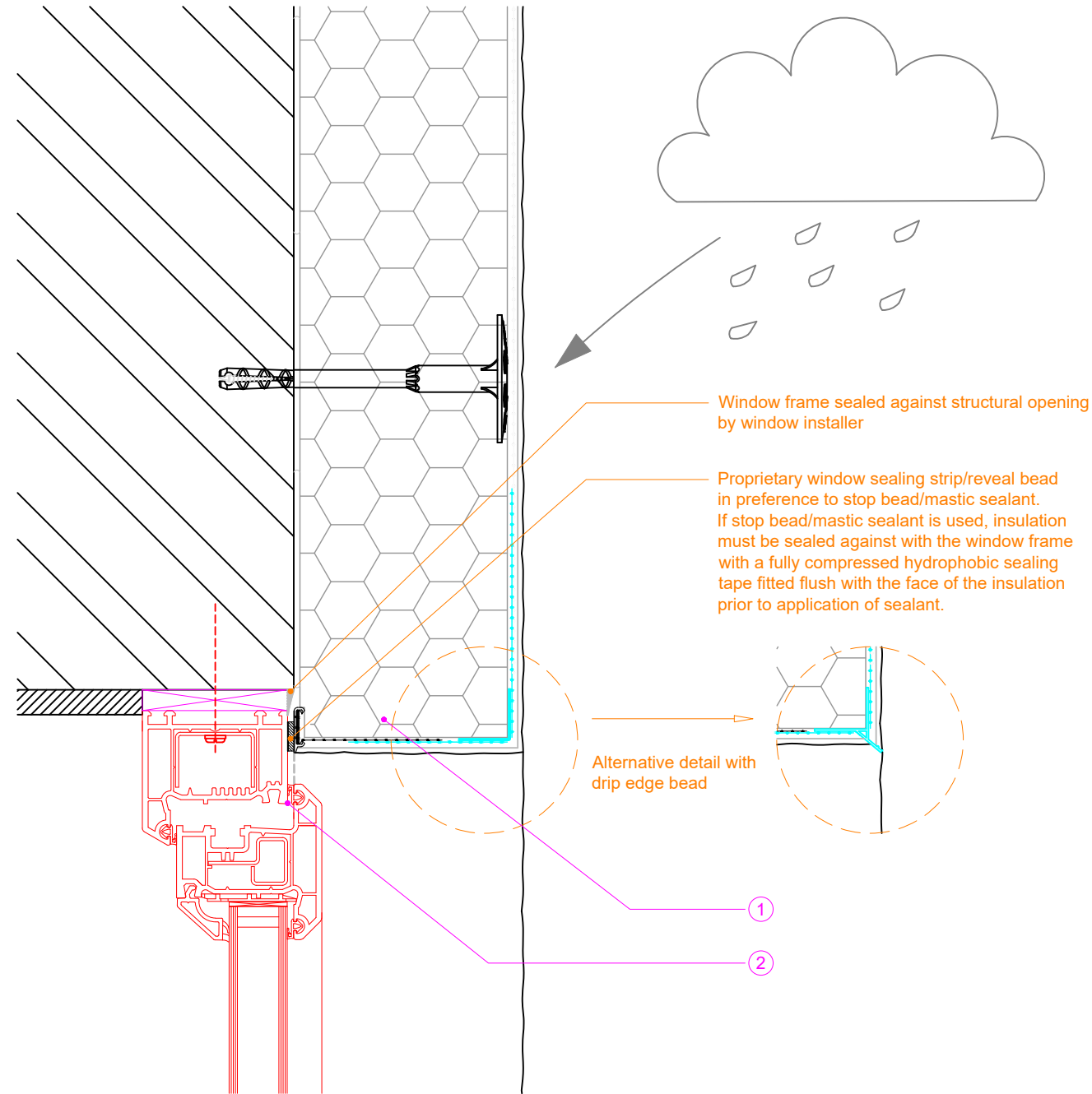

WEATHERING RISK

Risks: Water back-tracking to window frame.

Solutions:

- Windows frame sealed against structural opening and weathertight prior to installation of the EWI system.
- EWI system sealed against window frame at head using proprietary window sealing strip/reveals bead or sealing tape, stop bead and low-modulus sealant (see WRD-WJ001B).
- Drip edge corner bead at arris in lieu of standard corner bead to provide improved water shedding at render return into reveal at head.

TITLE:	Insulation over Flush Head
Dwg. No.	WRD-WH002
Rev.	-
Date:	18/12/2018

SPECIFICATION FOR WEATHERING AND THERMAL BRIDGE CONTROL

THERMAL BRIDGING RISK LEVEL

Note :

- All details indicate fixings that are thermally broken.



Amber if wall constructed in ≥ 225 mm solid brick. Not suitable for random stone constructions. Note that amber will increase the assessed inherent technical risk level in table B2 of PAS 2035 by 1.

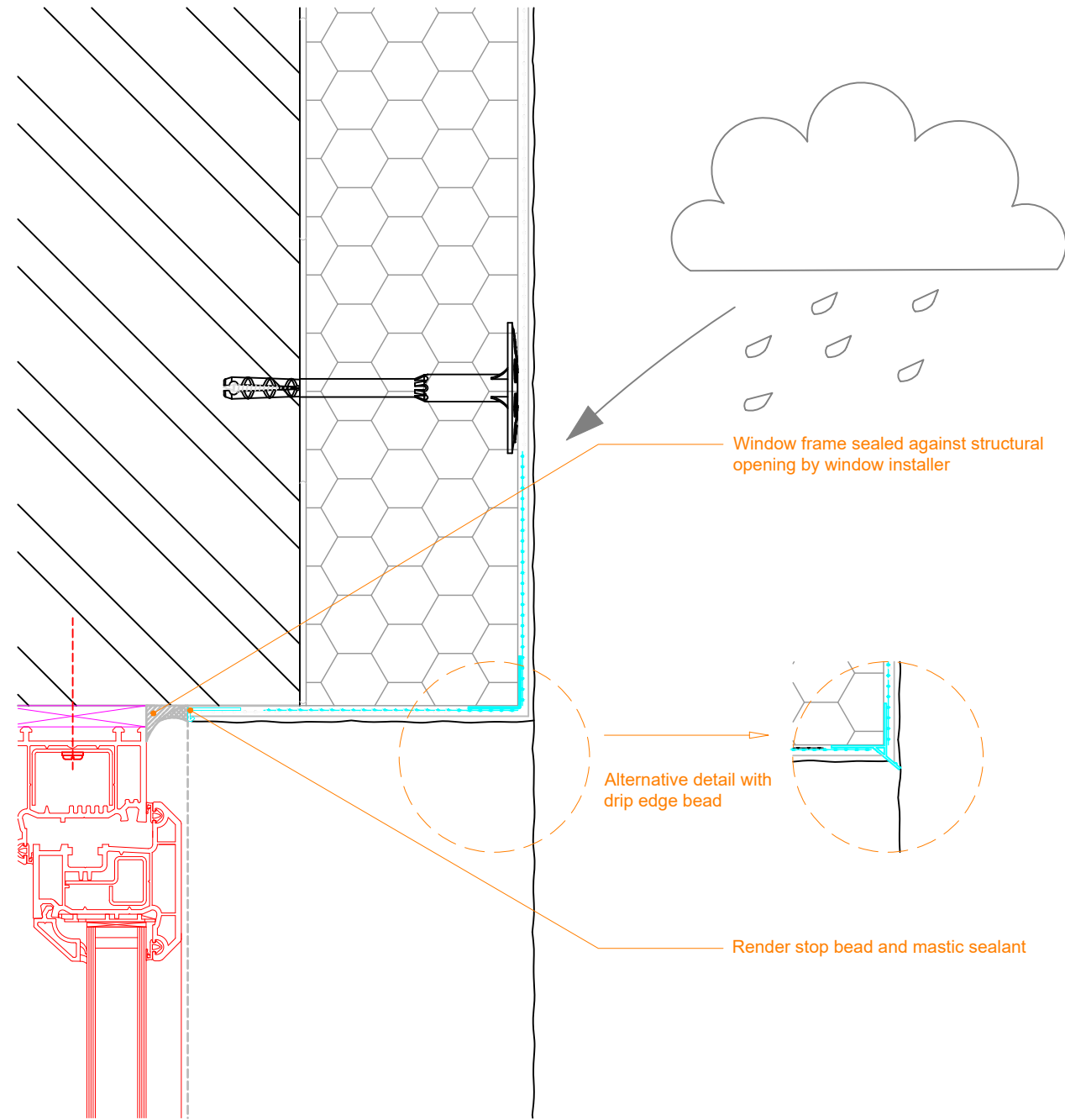

WEATHERING RISK

Risks: Water back-tracking to window frame.

Solutions:

- Windows frame sealed against structural opening and weathertight prior to installation of the EWI system.
- EWI system sealed against window frame at head using proprietary window sealing strip/reveals bead or sealing tape, stop bead and low-modulus sealant (see WRD-WJ001B).
- Drip edge corner bead at arris in lieu of standard corner bead to provide improved water shedding from render return into reveal at head.

TITLE:	Un-Insulated Head
Dwg. No.	WRD-WH003
Rev.	-
Date:	18/12/2018

THERMAL BRIDGING RISK LEVEL

Note :

- All details indicate fixings that are thermally broken.



Amber. Note that amber will increase the assessed inherent technical risk level in table B2 of PAS 2035 by 1.

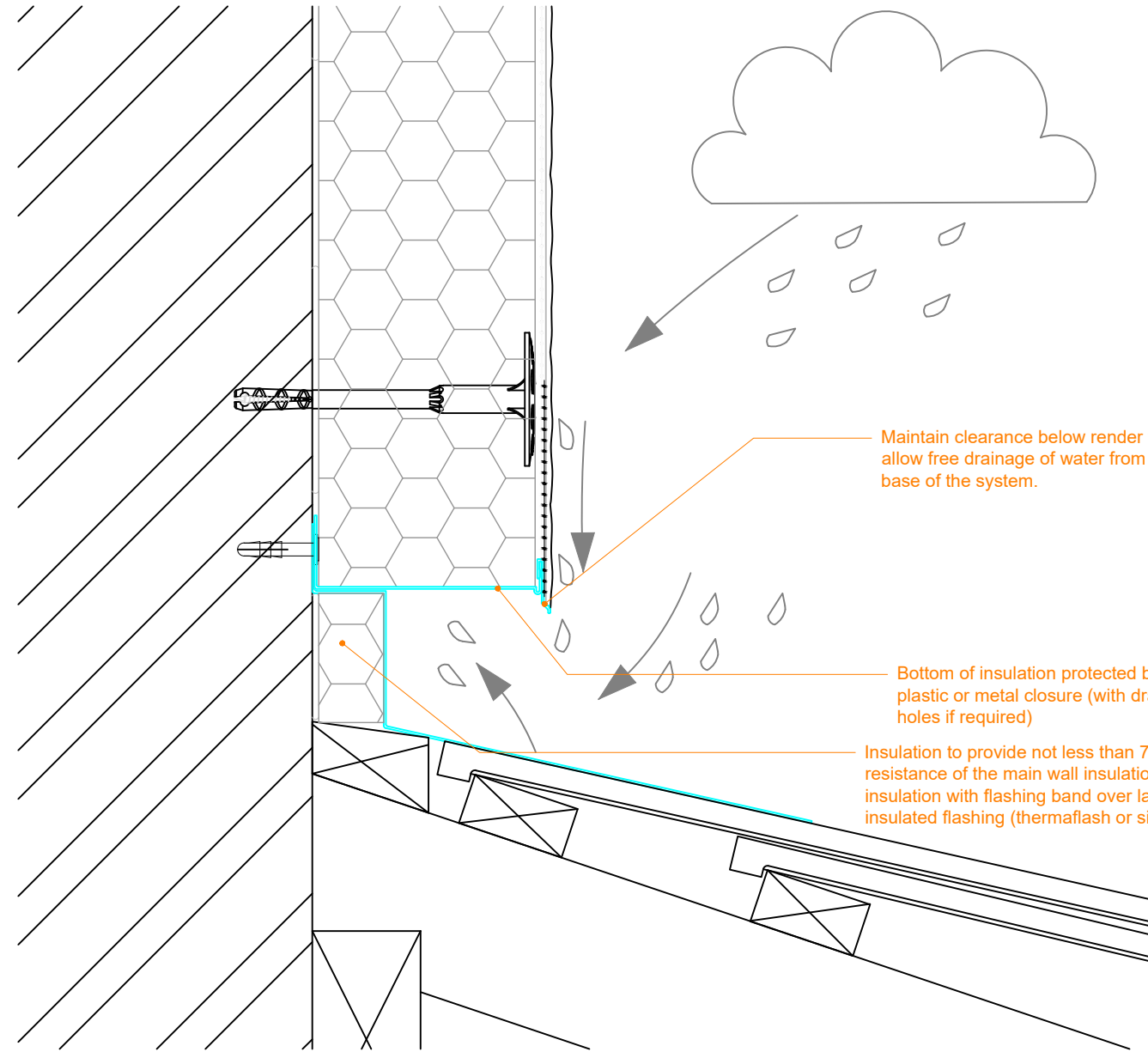

WEATHERING RISK

Risks: Inadequate free drainage of water from the bottom of the render prevents render surface from drying.

Solutions:

- Maintain a clear gap between the bottom edge of the render and the surface below. Bottom of the system protected by a plastic (low thermal conductivity) or metal starter track/base track.

TITLE:	Pitched Roof Abutment
Dwg. No.	WRD-RA001
Rev.	-
Date:	18/12/2018

THERMAL BRIDGING RISK LEVEL

Note :

- All details indicate fixings that are thermally broken.



Amber. Note that amber will increase the assessed inherent technical risk level in table B2 of PAS 2035 by 1.

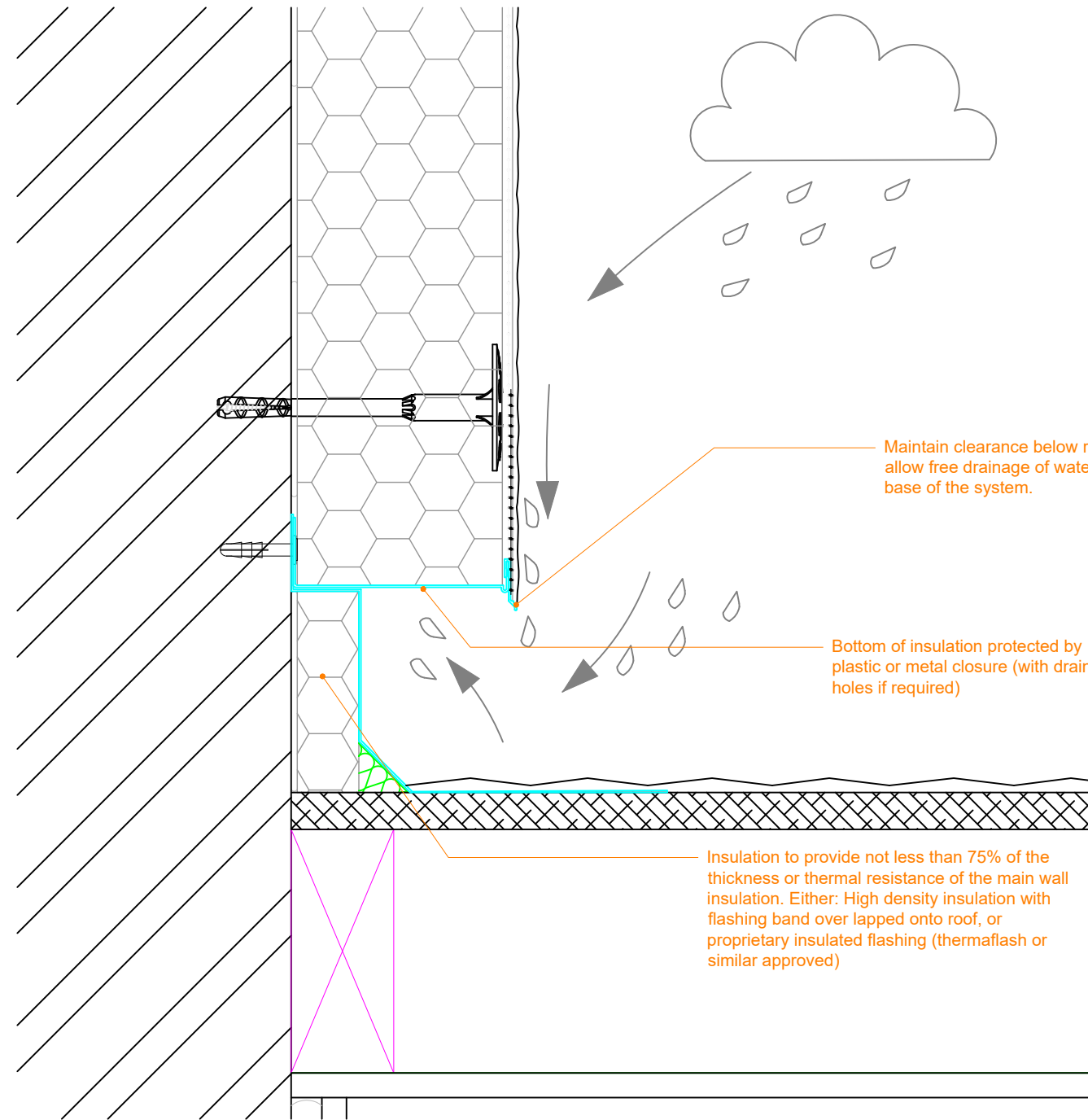

WEATHERING RISK

Risks: Inadequate free drainage of water from the bottom of the render prevents render surface from drying.

Solutions:

- Maintain a clear gap between the bottom edge of the render and the surface below. Bottom of the system protected by a plastic (low thermal conductivity) or metal starter track/base track.

TITLE:	Flat Roof Abutment
Dwg. No.	WRD-RA002
Rev.	-
Date:	18/12/2018

SPECIFICATION FOR WEATHERING AND THERMAL BRIDGE CONTROL

THERMAL BRIDGING RISK LEVEL

Note :

- All details indicate fixings that are thermally broken.



Green, no effect on risk level.

Captions :

- ① Ensure loft insulation extends across top of external wall insulation.
- ② System installed to underside of existing soffit and fascia or, if practicable, remove existing fascia and install system as far up the existing wall as possible

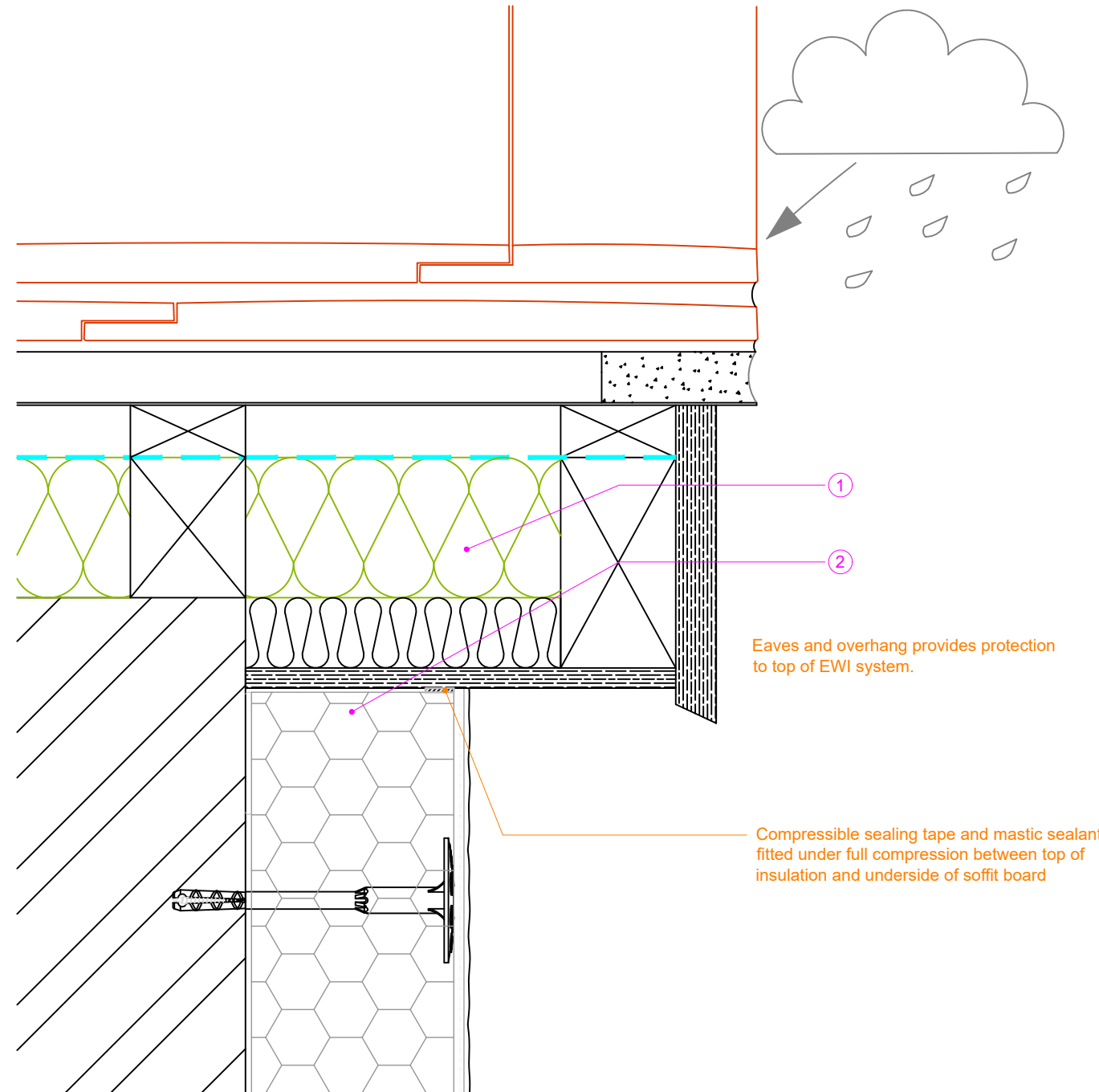

WEATHERING RISK

Risks: Low. Overhanging verge provides weathering protection to EWI system. Larger overhang offers greater protection.

Solutions: Roof extended as necessary to provide overhang to EWI system.

TITLE:	Extended/Overhanging Verge
Dwg. No.	WRD-V002
Rev.	-
Date:	18/12/2018

SPECIFICATION FOR WEATHERING AND THERMAL BRIDGE CONTROL

THERMAL BRIDGING RISK LEVEL

Note :

- All details indicate fixings that are thermally broken.



Green, no effect on risk level.

Captions :

- 1 Ensure ventilation pathway is maintained: It is critical that cross-flow ventilation is maintained.
- 2 Existing soffit board removed and system taken up entire wall to ensure continuity with loft insulation.
- 3 Loft insulation must extend across top of wall and across top of external wall insulation.

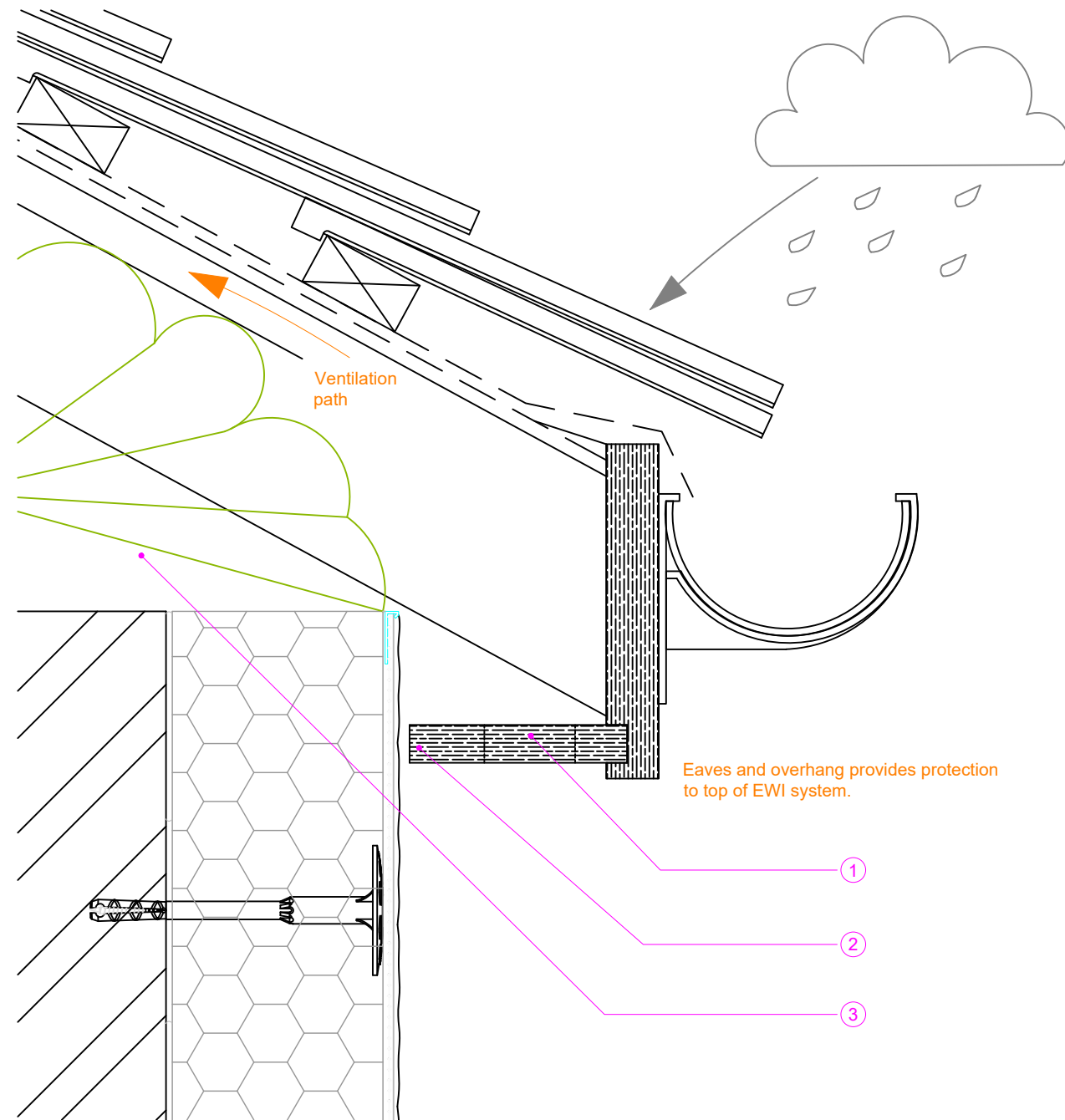

WEATHERING RISK

Risks: Low. EWI system protected by roof overhang at eaves.

Solutions: N/A

TITLE:	Extended/Overhanging Eaves (1)
Dwg. No.	WRD-E001
Rev.	-
Date:	18/12/2018

SPECIFICATION FOR WEATHERING AND THERMAL BRIDGE CONTROL

THERMAL BRIDGING RISK LEVEL

Note :

- All details indicate fixings that are thermally broken.



Green if ceiling height lower than top of EWI system.



Amber if ceiling height above top of EWI system. Note that amber will increase the assessed inherent technical risk level in table B2 of PAS 2035 by 1.

Captions :

- ① Ensure ventilation pathway is maintained: It is critical that cross-flow ventilation is maintained.
- ② Loft insulation must extend across top of wall and across top of external wall insulation.

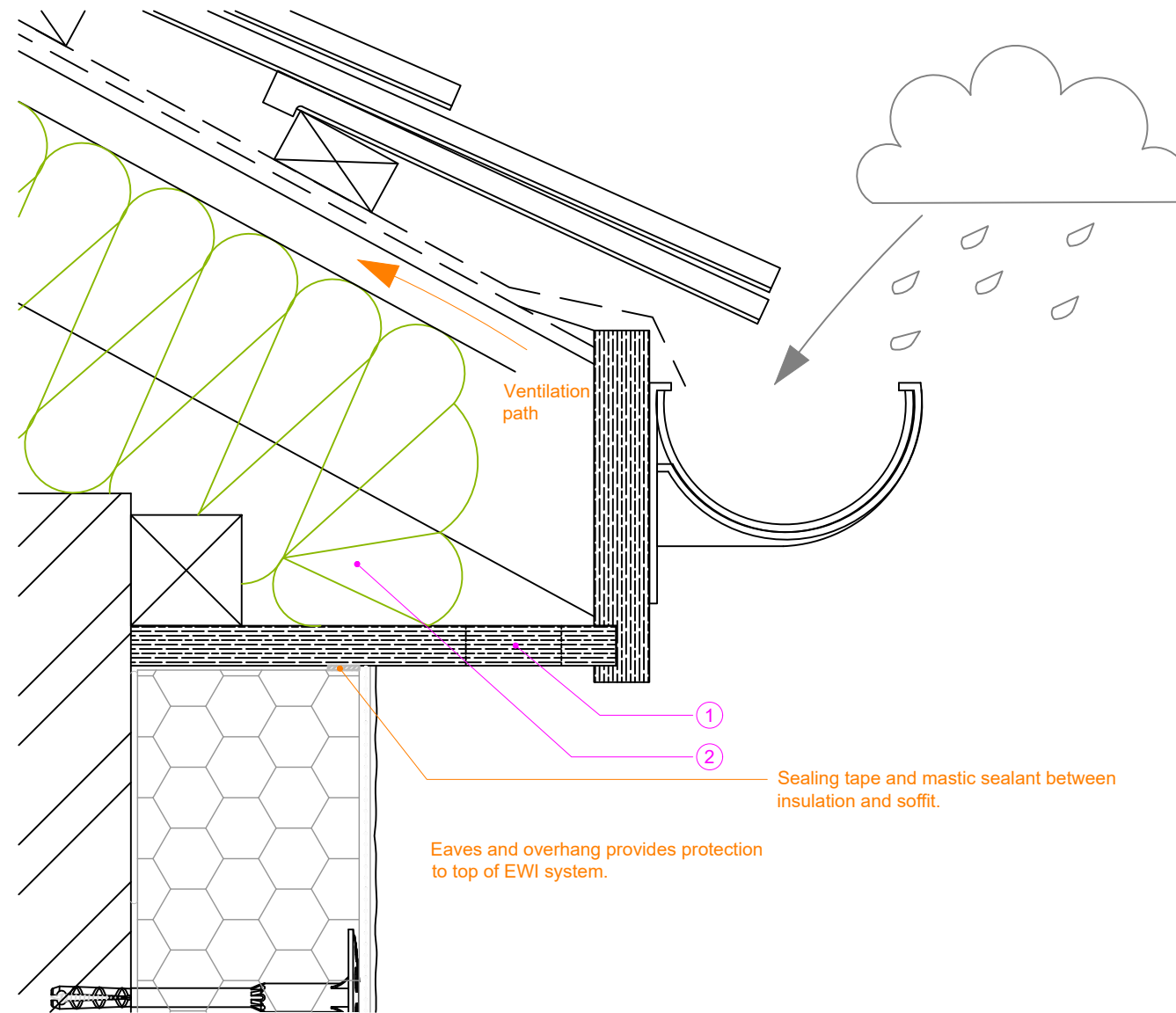

WEATHERING RISK

Risks: Low. EWI system protected by roof overhang at eaves.

Solutions: N/A

TITLE:	Extended/Overhanging Eaves (2)
Dwg. No.	WRD-E002
Rev.	-
Date:	18/12/2018

THERMAL BRIDGING RISK LEVEL

Note :

- All details indicate fixings that are thermally broken.



Green, no effect on risk level.

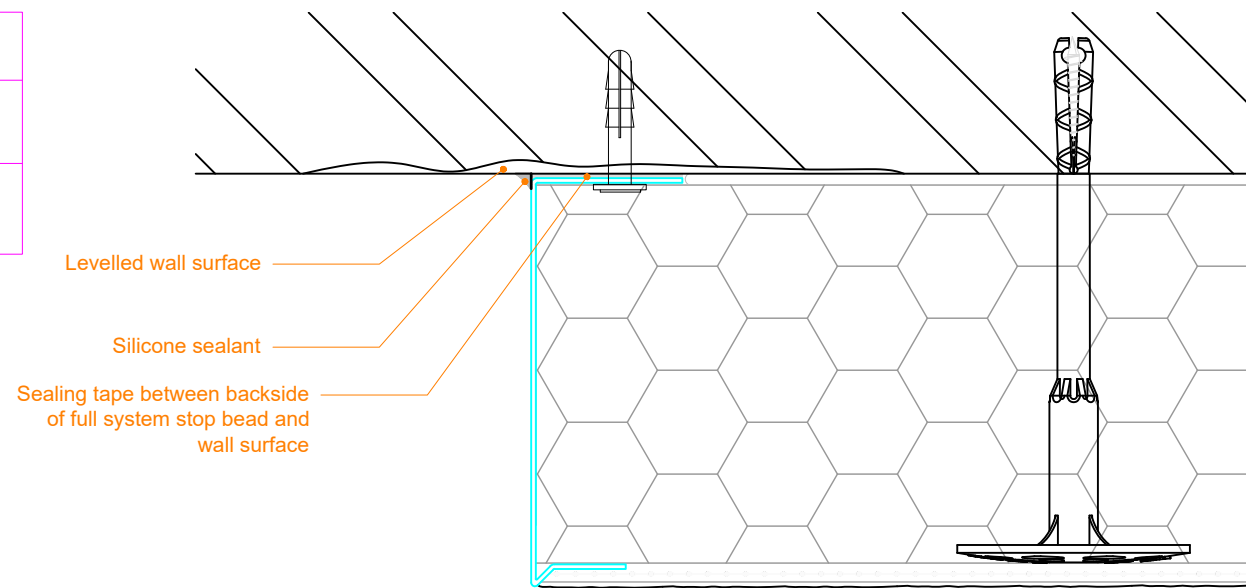

Plan Section

WEATHERING RISK

Risks:

- Inadequate seal between full system stop bead and wall surface allows water penetration behind EWI system.
- Adjoining sections of full system stop bead inadequately sealed: water ingress occurs.

Solutions:

- Surface against which full system stop bead is attached shall be filled/levelled to provide a flat surface against which a weathertight seal can be made.
- Full system stop bead sealed against wall face.
- Adjacent sections of full system stop bead joined together with metal connectors with seals both side of joint.

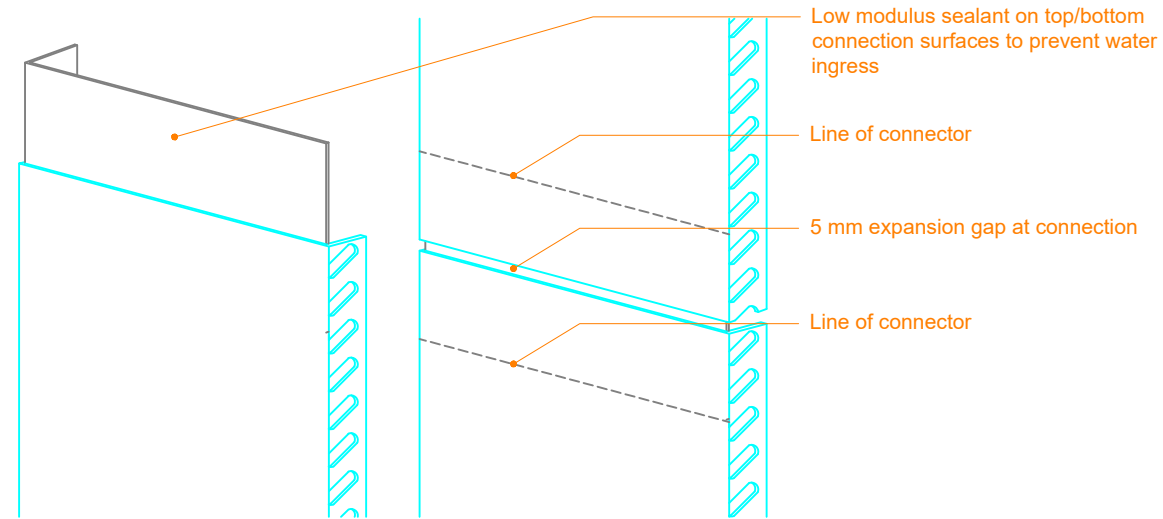

Isometric - Connector Detail

Title:	EWI Termination - with Full System Stop Bead
Dwg. No.	WRD-T001
Rev.	-
Date:	18/12/2018

SPECIFICATION FOR WEATHERING AND THERMAL BRIDGE CONTROL

THERMAL BRIDGING RISK LEVEL

Note :

- All details indicate fixings that are thermally broken.
- Movement of service boxes should be undertaken by the owner of the box, i.e. The utility company, or movement without consent would be an act of trespass.



Green, no effect on risk level.

Captions :

- ① Remove service box and re-position on the out side face of the EWI system using thermally broken supports/fixings.

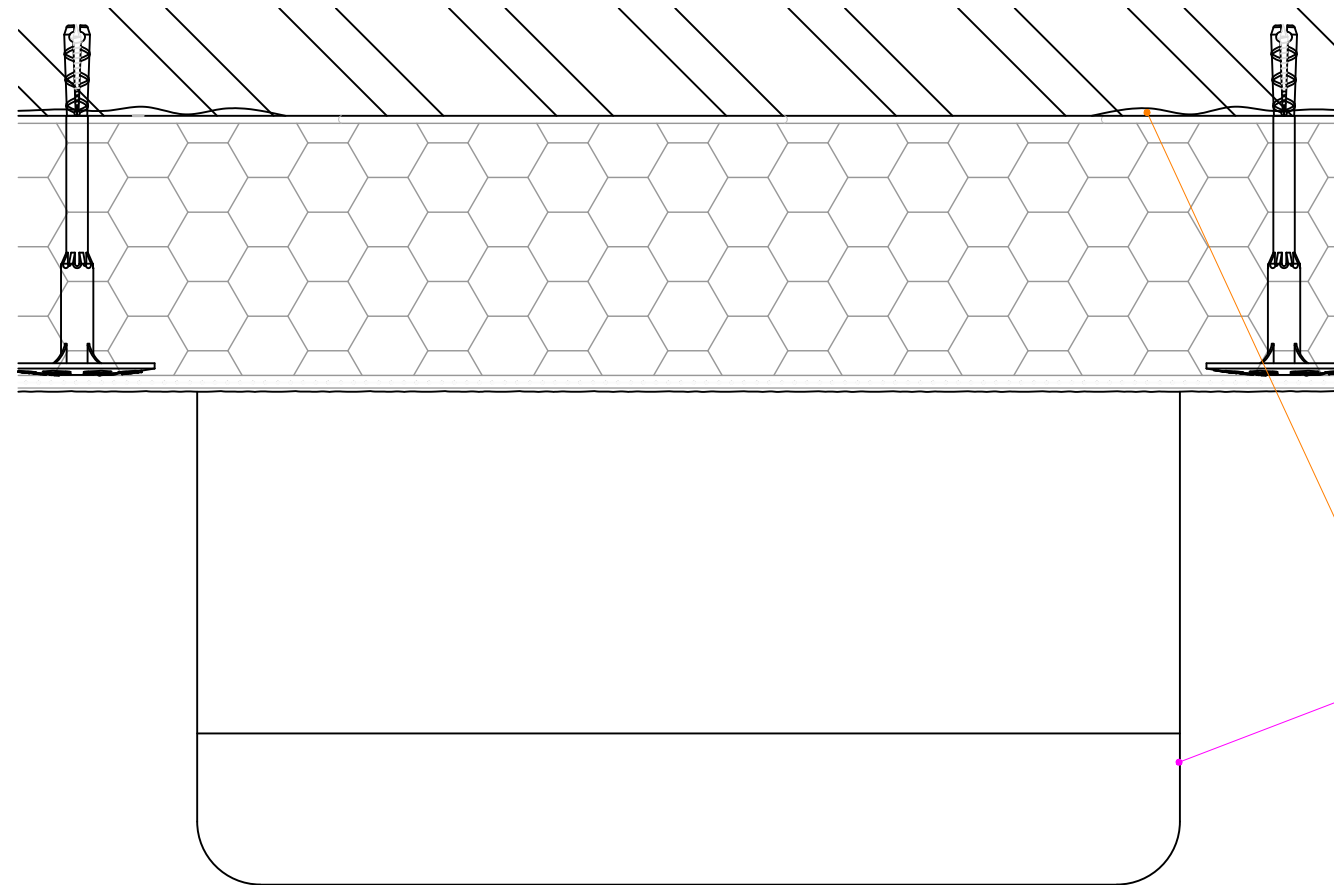

WEATHERING RISK

Risks: N/A

Solutions: N/A

Plan Section - Service Box Outside of EWI System

THERMAL BRIDGING RISK LEVEL

Note :

- All details indicate fixings that are thermally broken.
- Movement of service boxes should be undertaken by the owner of the box, i.e. The utility company, or movement without consent would be an act of trespass.



Amber. Note that amber will increase the assessed inherent technical risk level in table B2 of PAS 2035 by 1.

Captions :

- ② Provide external grade cavity closer with thermal resistance $\geq 75\%$ of wall insulation.
- ③ For gap to sides/edges of box refer to 'Specification for the installation of external wall insulation ensuring safety and operation of fuel burning appliances V.1.0 31st March 2017'. Surface mounted gas meter boxes require a min. gap of 25 mm for access and maintenance.

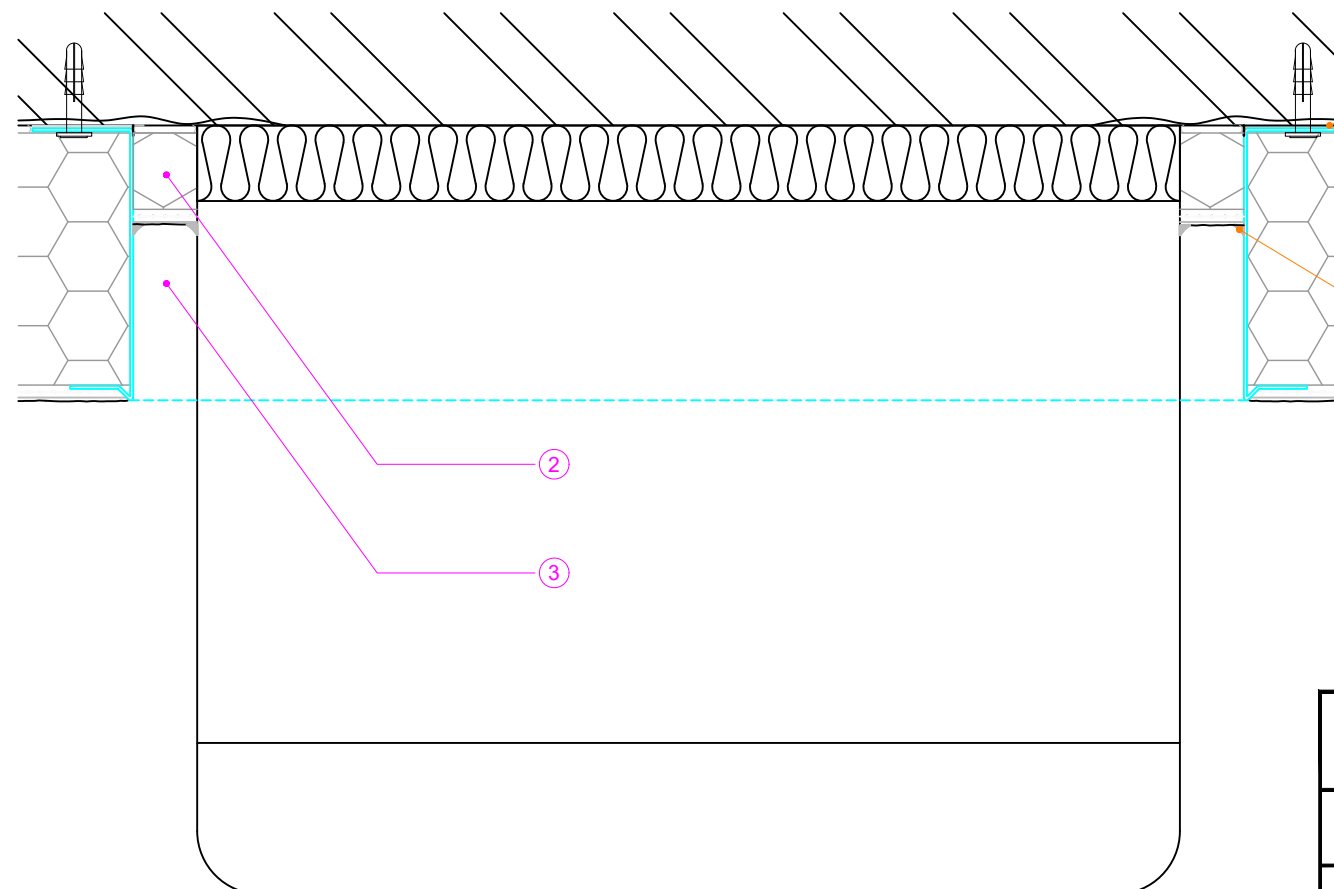

Plan Section - Thin Board Insulation behind Service Box

Title:	Service Box - Removable Box
Dwg. No.	WRD-SB001
Rev.	-
Date:	18/12/2018

SPECIFICATION FOR WEATHERING AND THERMAL BRIDGE CONTROL

THERMAL BRIDGING RISK LEVEL

Note :

- All details indicate fixings that are thermally broken.
- Movement of service boxes should be undertaken by the owner of the box, i.e. The utility company, or movement without consent would be an act of trespass.



Green, no effect on risk level.

Captions :

- ① Remove service box and re-position on the out side face of the EWI system using thermally broken supports/fixings.

WEATHERING RISK

Risks: N/A

Solutions: N/A

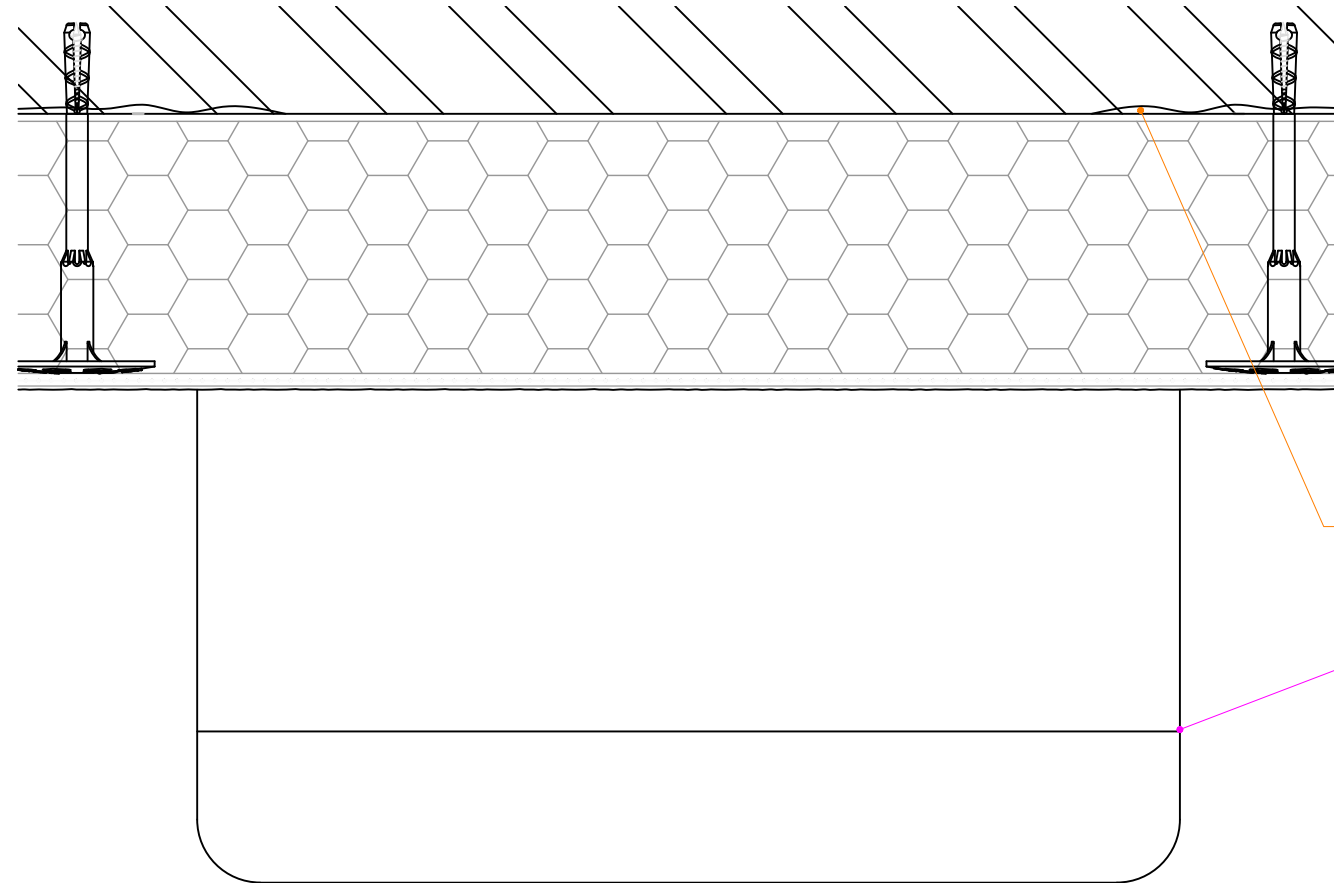

Leveled wall surface

①

Plan Section - Service Box Outside of EWI System

THERMAL BRIDGING RISK LEVEL

Note :

- All details indicate fixings that are thermally broken.
- Movement of service boxes should be undertaken by the owner of the box, i.e. The utility company, or movement without consent would be an act of trespass.



Amber. Note that amber will increase the assessed inherent technical risk level in table B2 of PAS 2035 by 1.

Captions :

- ② Provide insulation within service box where practicable/missible.

Refer to 'Specification for the installation of external wall insulation ensuring safety and operation of fuel burning appliances V.1.0 31st March 2017'.

Leveled wall surface

Low modulus sealant on top/bottom connection surfaces to prevent water ingress

Install system flush to sides of service box and provide seal against box (refer to EWI manufacturer's detail).

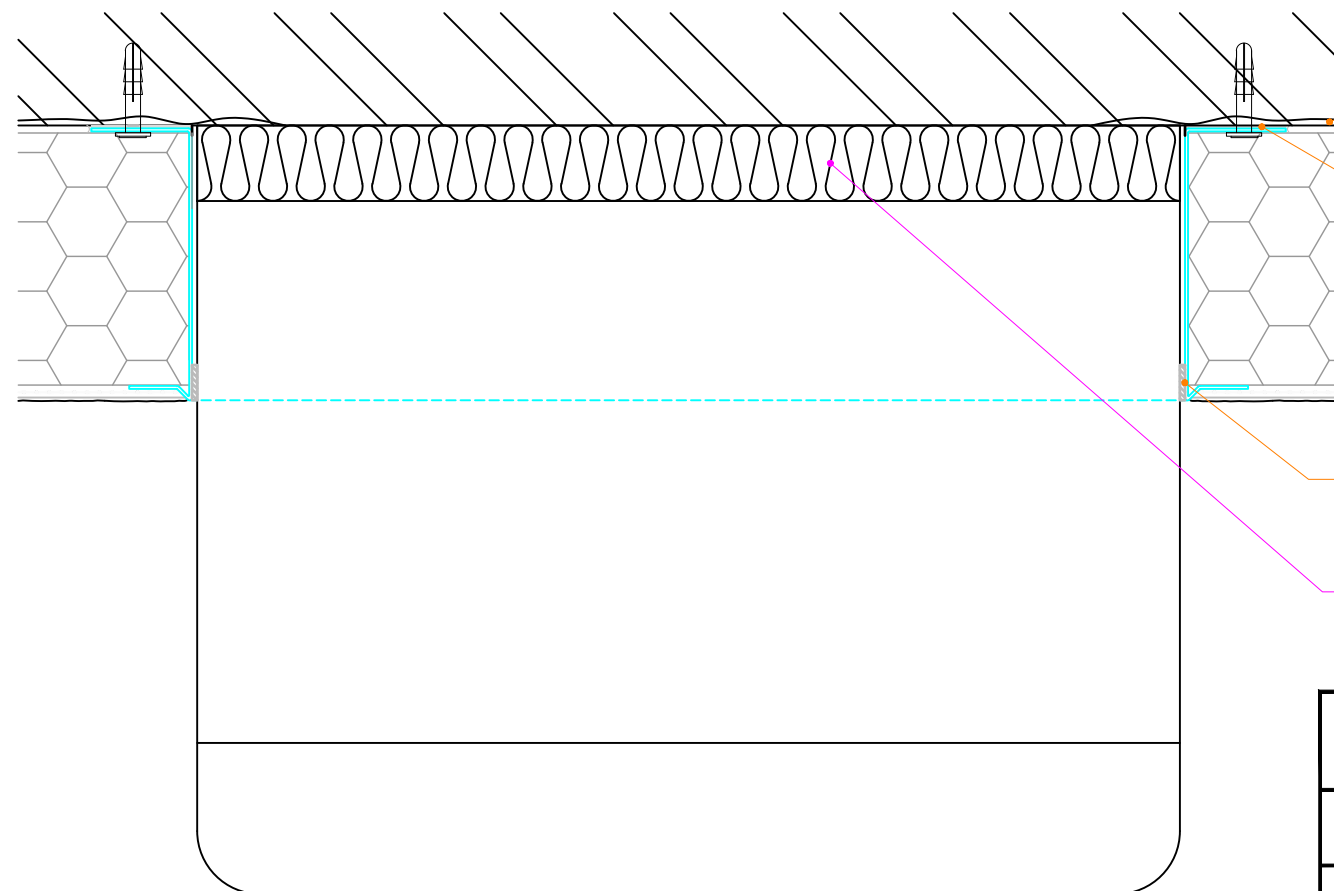

②

Plan Section - Thin Board Insulation behind Service Box

Title:	Service Box - Front Access
Dwg. No.	WRD-SB002
Rev.	-
Date:	18/12/2018

SPECIFICATION FOR WEATHERING AND THERMAL BRIDGE CONTROL

THERMAL BRIDGING RISK LEVEL

Note :

- All details indicate fixings that are thermally broken.



Green, no effect on risk level.

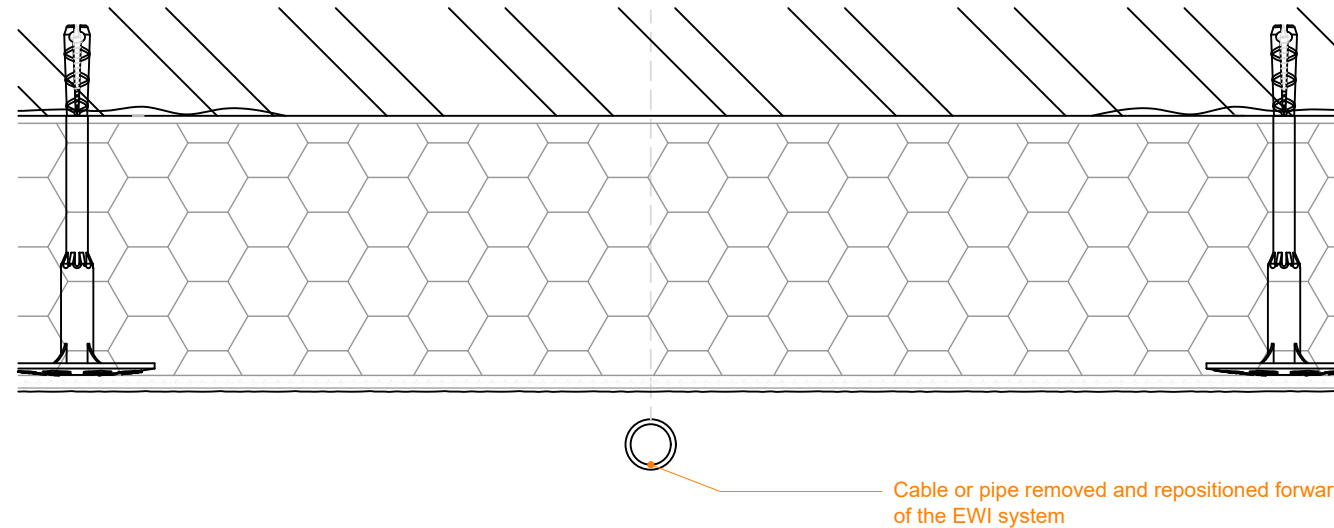

Plan Section - External Pipe/Cable

WEATHERING RISK

Risks: N/A

Solutions: N/A

THERMAL BRIDGING RISK LEVEL

Note :

- All details indicate fixings that are thermally broken.



Amber. Note that amber will increase the assessed inherent technical risk level in table B2 of PAS 2035 by 1.

Captions :

- ① Provide insulation within gas pipe/electrical services enclosure where practicable/permissible.

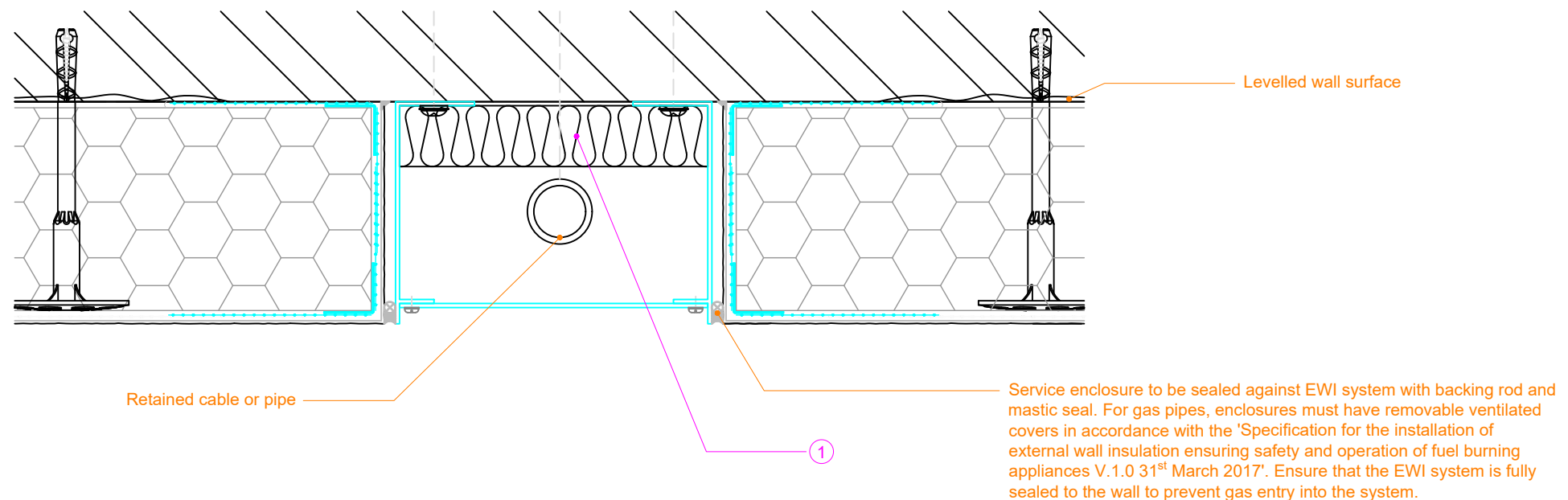

Plan Section - Thin Board Insulation behind Gas/Electrical Service Enclosure

Title:	Gas Pipe / Electrical Cables
Dwg. No.	WRD-G001
Rev.	-
Date:	18/12/2018

SPECIFICATION FOR WEATHERING AND THERMAL BRIDGE CONTROL

THERMAL BRIDGING RISK LEVEL

Note :

- All details indicate fixings that are thermally broken.



Green, no effect on risk level.

Captions :

- ① Thermally broken, cantilevered through fixing. Refer to manufacturer for allowable loadings.

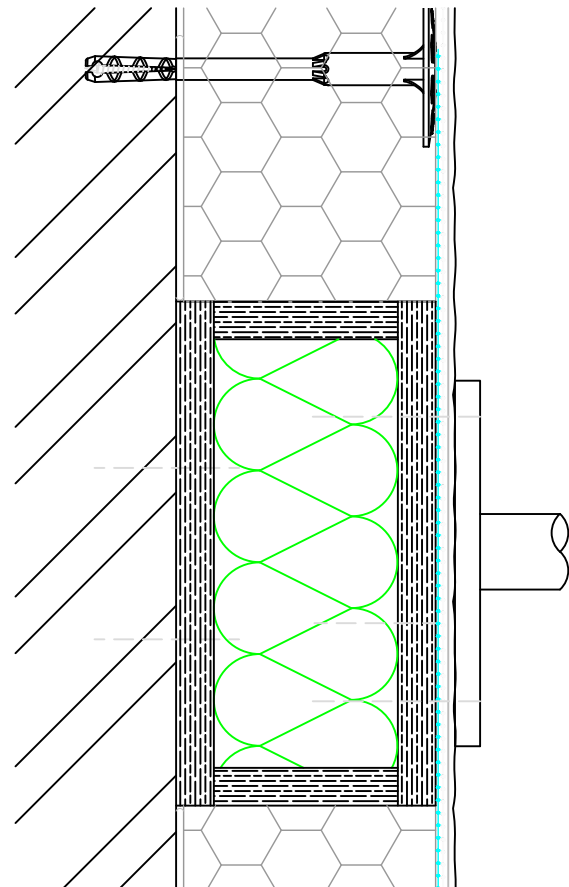

Insulated Box Pattern

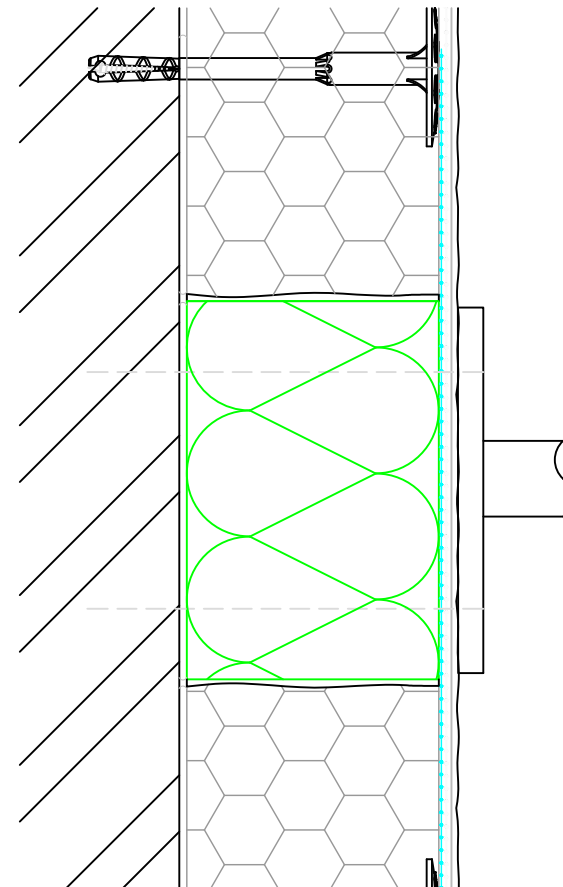

HD Insulation Block

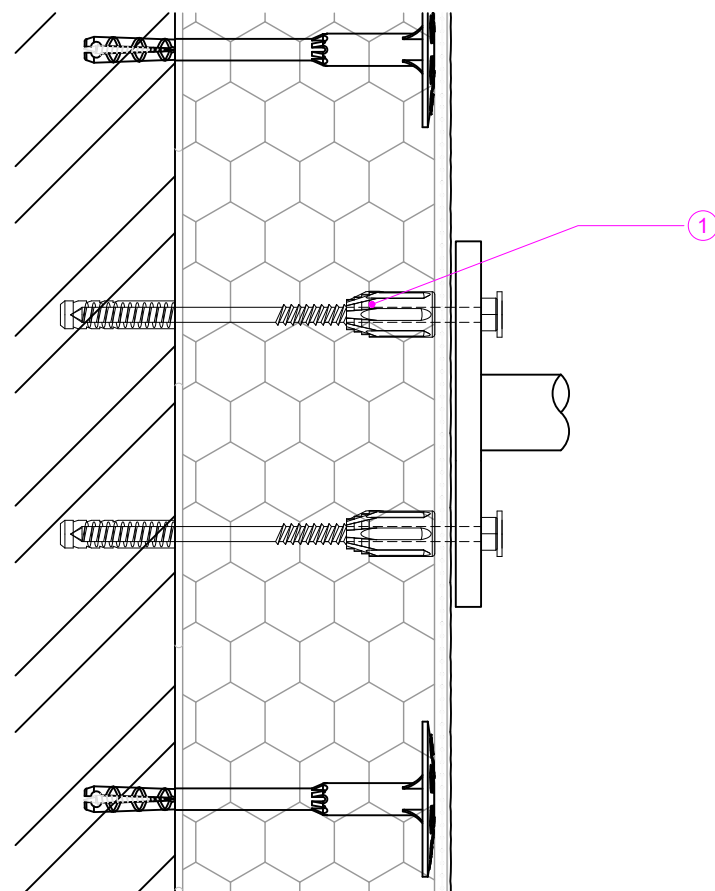

Thermal Broken Fixing

WEATHERING RISK

Risks: Water ingress into insulation at fixings.

Solutions:

- Ensure fixings are sealed against render with EPDM gaskets or proprietary waterproof sealant.

Title:	Heavy Weight External Fixture
Dwg. No.	WRD-EFF001
Rev.	-
Date:	18/12/2018

SPECIFICATION FOR WEATHERING AND THERMAL BRIDGE CONTROL

THERMAL BRIDGING RISK LEVEL

Note :

- All details indicate fixings that are thermally broken.



Green, no effect on risk level.

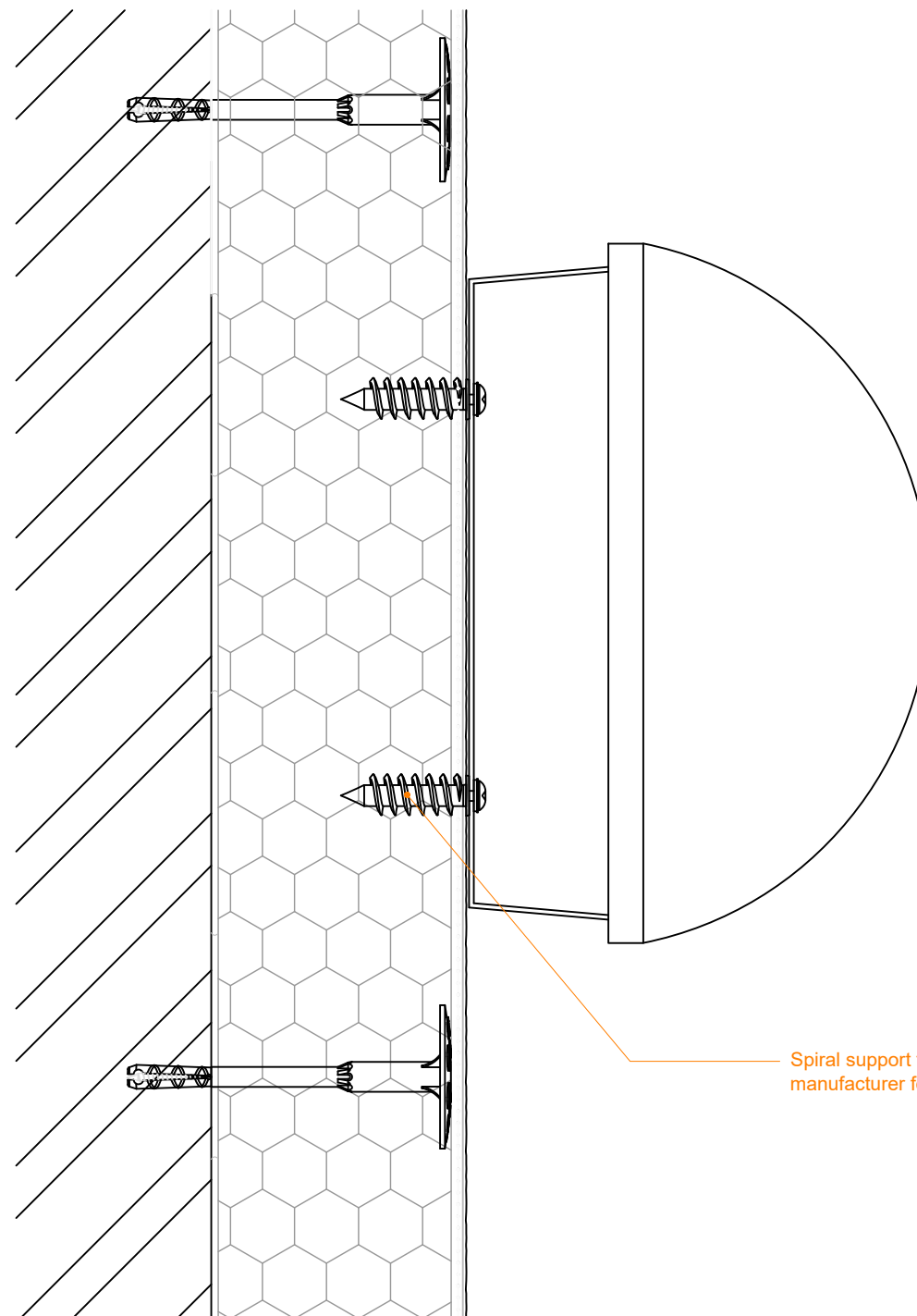

WEATHERING RISK

Risks: Water ingress into insulation at fixings.

Solutions:

- Ensure fixings are sealed against render with EPDM gaskets or proprietary waterproof sealant.

Title:	Light Weight External Fixture
Dwg. No.	WRD-EFF002
Rev.	-
Date:	18/12/2018